

# ROCKBOARD®

by WARWICK



# Innovation from the ground up



Introducing our range of **RockBoard®** pedalboards and accessories, full of innovation and versatile solutions for the world of pedalboards.

We created these products based on feedback we received from hard-working musicians around the world. The result is a series of pedalboard products that are carefully crafted with an attention to detail and a desire to provide you with the best solutions possible.

Built using German ingenuity and precision engineering, **RockBoard®** pedalboards are both incredibly lightweight and exceptionally durable. Their ultra-light aluminum construction ensures superior portability, and the innovative design provides optimal pedal mounting and space-savings, all of which integrate seamlessly thanks to our **RockBoard®** cables.

But the innovation doesn't stop there! Enter the MOD (Modular Patch-bays), our revolutionary new addition to pedalboard customization. Our MODs integrate perfectly with your **RockBoard®** and offer a multitude of useful solutions, such as our innovative LED lights that illuminate your pedalboard for better visibility and added flair.

Another feature that truly sets **RockBoard®** apart from the competition is our QuickMount® system, ingeniously designed to perfectly align with the slotted grid on the board, for optimal placement and space-savings. Pair that with our PedalSafe® to protect your prized pedals from wear, tear and the elements, preserving them for years to come.

Our range of **RockBoard®** pedalboards isn't just any regular pedalboard. It's your all-in-one solution, crafted with advanced German technology, ideal for seasoned professionals and budding enthusiasts alike. You can trust in **RockBoard®**!

**Nicolas Wilfer, CEO**  
Warwick GmbH & Co Music Equipment KG

# ROCKBOARD®

by WARWICK

Pedalboard Series	3 - 6
Gig Bags, Flight Cases	7
Add-Ons	8 - 9
LED Lights	10
MODs and Supports	11 - 13
In-Ear Monitoring Headphone Amplifiers	14
QuickMount® System	15 - 17
PedalSafe®	18 - 22
Power Supplies	23 - 24
Power Cables	26 - 28
Instrument Cables	29
Patch Cables	30
PatchWorks® (BYO)	31
Connectors	32
XLR, TRS, Looper/Switcher Cables	33
MIDI Cables	34
Pedal Bags	35
Suitcases	36
StageTuner	37
Sound Buffer, Power Attenuator	38
Accessories	39 - 40

[Click to view products](#)

WARWICK®, ROCKBOARD®, PEDALSAFE®, and QUICKMOUNT® are the trademarks of Warwick GmbH & Co. Music Equipment KG ("Warwick"), which may be registered in one or several categories of goods with the United States Patent & Trademark Office. Some of the aforementioned trademarks may be registered in one or several categories of goods in certain other territories. This is not a comprehensive list of all trademarks of Warwick and specifically does not include any common law trademarks of Warwick. All other names and marks not mentioned herein are the trade names, trademarks or service marks of their respective owners.

# New sizes to fit any rig



Click to watch video

## RockBoard® Pedalboards

The ingenious design of our RockBoard® pedalboards make them lightweight, rigid and rugged. Built using a single sheet of cold-rolled aluminum and U-shaped vertical support braces, the RockBoard® is one of the strongest pedalboards on the market. Thanks to the innovative slot-based grid design that allows you to easily hide and organize your cables and secure your pedals, optimizing your setup has never been easier. In addition to several new sizes, new and improved features for the RockBoard® line include additional MOD slots, increased versatility in power supply placement, improved pedalboard bags, stronger flight cases and brand-new accessories!

- Sturdy and light, cold rolled aluminum construction
- Slotted design for easy pedal mounting
- Mounting holes for RockBoard® LED Light (sold separately)
- U-shaped support braces
- 10° angled surface
- Seamless, black powder-coated surface



### Duo 2.0

31.8 x 14.2 cm / 12.52" x 5.59"

with Gig Bag RBO B 2.0 DUO B



### Duo 2.1

47.0 x 14.2 cm / 18.50" x 5.59"

with Gig Bag RBO B 2.1 DUO B

with Flight Case RBO B 2.1 DUO C



### Duo 2.2

62.2 x 14.2 cm / 24.49" x 5.59"

with Gig Bag RBO B 2.2 DUO B

with Flight Case RBO B 2.2 DUO C



### Duo 2.3

72.2 x 14.2 cm / 28.43" x 5.59"

with Gig Bag RBO B 2.3 DUO B

with Flight Case RBO B 2.3 DUO C



### Tres 3.0

44.2 x 23.6 cm / 17.40" x 9.29"

with Gig Bag	RBO B 3.0 TRES B
with Flight Case	RBO B 3.0 TRES C



### Quad 4.1

47.0 x 33.0 cm / 18.50" x 12.99"

with Gig Bag	RBO B 4.1 QUAD B
with Flight Case	RBO B 4.1 QUAD C

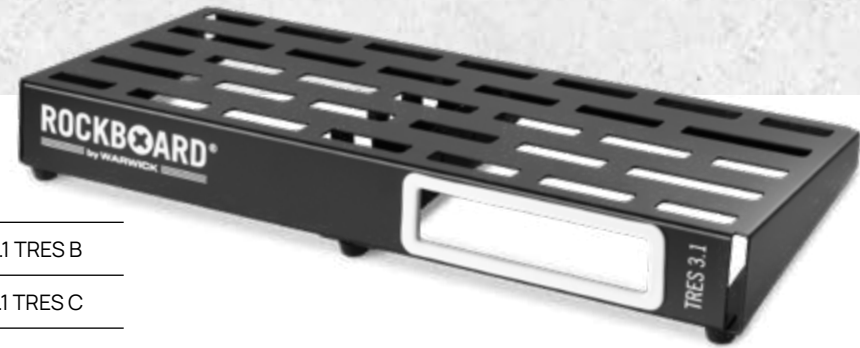

### Tres 3.1

52.2 x 23.6 cm / 20.55" x 9.29"

with Gig Bag	RBO B 3.1 TRES B
with Flight Case	RBO B 3.1 TRES C



### Quad 4.2

62.2 x 33.0 cm / 24.49" x 12.99"

with Gig Bag	RBO B 4.2 QUAD B
with Flight Case	RBO B 4.2 QUAD C



### Tres 3.2

59.8 x 23.6 cm / 23.54" x 9.29"

with Gig Bag	RBO B 3.2 TRES B
with Flight Case	RBO B 3.2 TRES C



### Quad 4.3

82.8 x 33.0 cm / 32.60" x 12.99"

with Gig Bag	RBO B 4.3 QUAD B
with Flight Case	RBO B 4.3 QUAD C

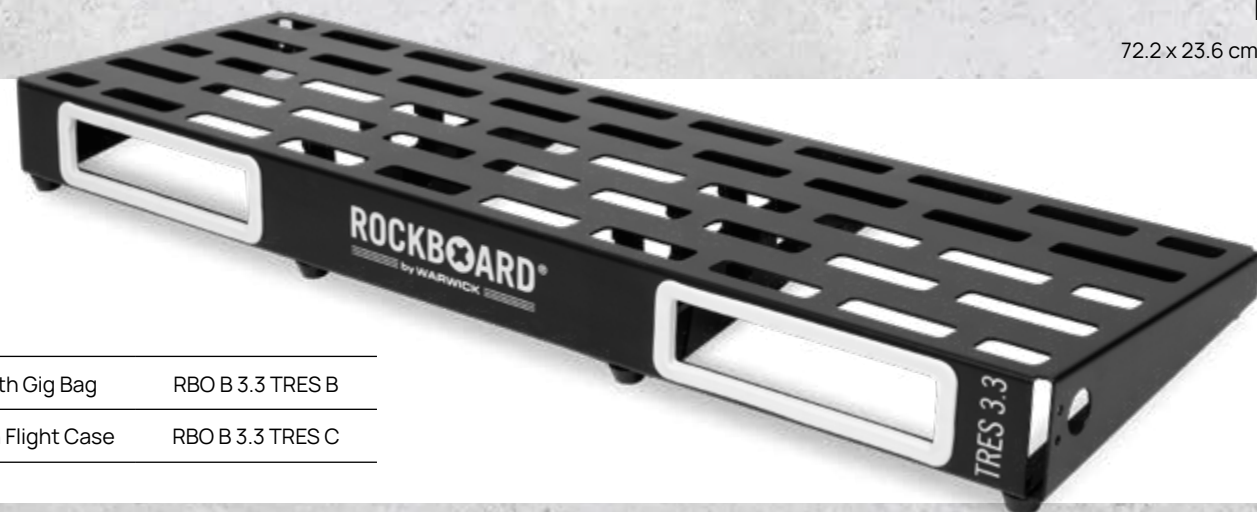

### Tres 3.3

72.2 x 23.6 cm / 28.43" x 9.29"

with Gig Bag	RBO B 3.3 TRES B
with Flight Case	RBO B 3.3 TRES C



### Quad 4.4

72.2 x 33.0 cm / 28.43" x 12.99"

with Gig Bag	RBO B 4.4 QUAD B
with Flight Case	RBO B 4.4 QUAD C

# Space for up to 30 pedals!



## Cinque 5.3

82.0 x 42.4 cm / 32.28" x 16.69"



with Gig Bag	RBO B 5.3 CINQUE B
with Flight Case	RBO B 5.3 CINQUE C

## Cinque 5.3 MAX

82.6 x 49.8 cm / 32.52" x 19.61"



with Gig Bag	RBO B 5.3 CINQ MAX B
with Flight Case	RBO B 5.3 CINQ MAX C

## Cinque 5.2

62.2 x 42.4 cm / 24.49" x 16.69"



with Gig Bag	RBO B 5.2 CINQUE B
with Flight Case	RBO B 5.2 CINQUE C

## Cinque 5.4

100.2 x 42.4 cm / 39.45" x 16.69"



with Gig Bag	RBO B 5.4 CINQUE B
with Flight Case	RBO B 5.4 CINQUE C

# RockBoard® size comparisons

## Duo 2.0



For approx. 3 to 5 effects pedals (depending on size).  
Dimensions: 31.8 x 14.2 cm / 12.52" x 5.59".  
Weight: 0.5 kg / 1.1 lbs.

## Duo 2.1



For approx. 4 to 7 effects pedals (depending on size).  
Dimensions: 47.0 x 14.2 cm / 18.50" x 5.59".  
Weight: 0.7 kg / 1.6 lbs.

## Duo 2.2



For approx. 5 to 9 effects pedals (depending on size).  
Dimensions: 62.2 x 14.2 cm / 24.49" x 5.59".  
Weight: 0.9 kg / 2 lbs.

## Duo 2.3



For approx. 7 to 11 effects pedals (depending on size).  
Dimensions: 72.2 x 14.2 cm / 28.43" x 5.59".  
Weight: 1 kg / 2.2 lbs.

## Tres 3.0

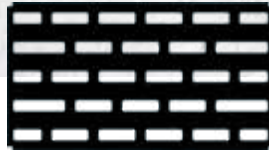

For approx. 5 to 10 effects pedals (depending on size).  
Dimensions: 44.2 x 23.6 cm / 17.40" x 9.29".  
Weight: 0.95 kg / 2.1 lbs.

## Tres 3.1

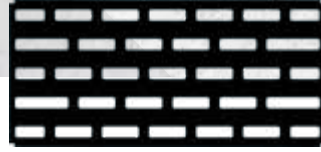

For approx. 5 to 10 effects pedals (depending on size).  
Dimensions: 52.2 x 23.6 cm / 20.55" x 9.29".  
Weight: 1.2 kg / 2.7 lbs.

## Tres 3.2



For approx. 7 to 12 effects pedals (depending on size).  
Dimensions: 59.8 x 23.6 cm / 23.54" x 9.29".  
Weight: 1.3 kg / 2.9 lbs.

## Tres 3.3

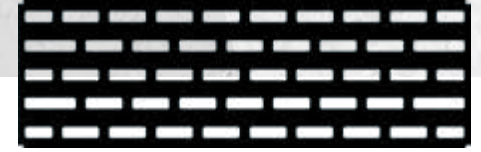

For approx. 9 to 14 effects pedals (depending on size).  
Dimensions: 72.2 x 23.6 cm / 28.43" x 9.29".  
Weight: 1.5 kg / 3.3 lbs.

## Quad 4.1

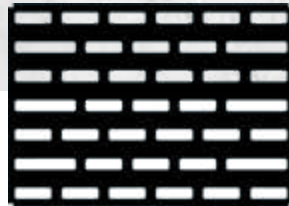

For approx. 7 to 12 effects pedals (depending on size).  
Dimensions: 47.0 x 33.0 cm / 18.50" x 12.99".  
Weight: 1.5 kg / 3.3 lbs.

## Quad 4.2

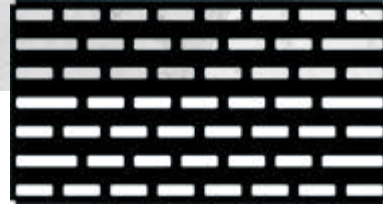

For approx. 9 to 15 effects pedals (depending on size).  
Dimensions: 62.2 x 33.0 cm / 24.49" x 12.99".  
Weight: 2.05 kg / 4.5 lbs.

## Quad 4.3

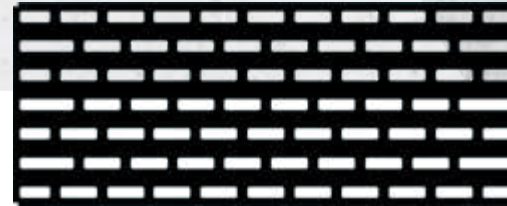

For approx. 10 to 20 effects pedals (depending on size).  
Dimensions: 82.8 x 33.0 cm / 32.60" x 12.99".  
Weight: 2.4 kg / 5.3 lbs.

## Quad 4.4

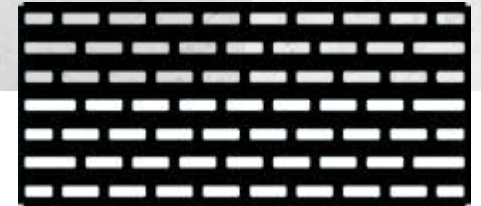

For approx. 9 to 18 effects pedals (depending on size).  
Dimensions: 72.2 x 33.0 cm / 28.43" x 12.99".  
Weight: 5 kg / 11 lbs.

## Cinque 5.2

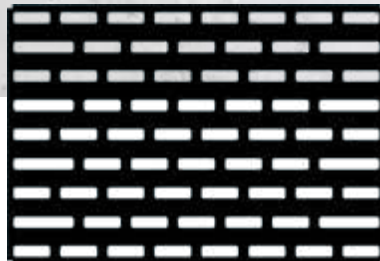

For approx. 10 to 20 effects pedals (depending on size).  
Dimensions: 62.2 x 42.4 cm / 24.49" x 16.69".  
Weight: 3.95 kg / 8.7 lbs.

## Cinque 5.3

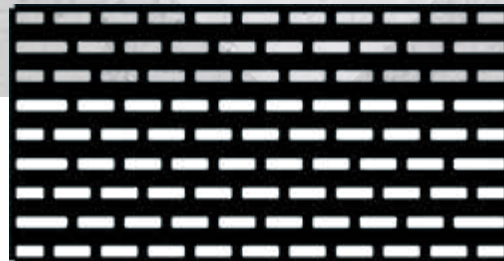

For approx. 15 to 25 effects pedals (depending on size).  
Dimensions: 82.0 x 42.4 cm / 32.28" x 16.69".  
Weight: 4.5 kg / 9.9 lbs.

## Cinque 5.3 MAX

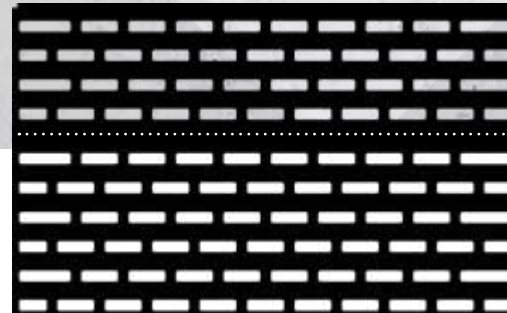

For approx. 15 to 25 effects pedals (depending on size).  
Dimensions: 82.6 x 49.8 cm / 32.52" x 19.61".  
Weight: 6.5 kg / 14.3 lbs.

## Cinque 5.4

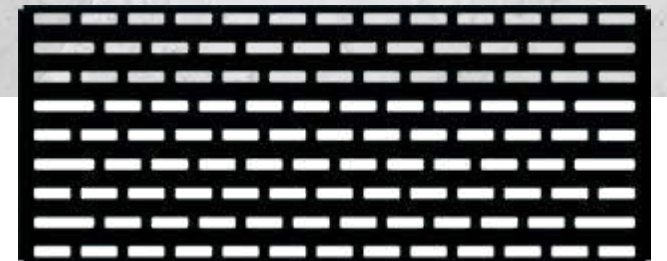

For approx. 20 to 30 effects pedals (depending on size).  
Dimensions: 100.2 x 42.4 cm / 39.45" x 16.69".  
Weight: 9.55 kg / 21.1 lbs.

# Road ready protection

Each RockBoard® pedalboard comes with your choice of either a road-ready Flight Case or a soft and durable Gig Bag.

## Gig Bags



## Flight Cases



RockBoard® Pedalboard	RockBoard® Professional Gig Bag Product No.
DUO 2.0	RBO BAG 2.0 DUO
DUO 2.1	RBO BAG 2.1 DUO
DUO 2.2	RBO BAG 2.2 DUO
DUO 2.3	RBO BAG 2.3 DUO
TRES 3.0	RBO BAG 3.0 TRES
TRES 3.1	RBO BAG 3.1 TRES
TRES 3.2	RBO BAG 3.2 TRES
TRES 3.3	RBO BAG 3.3 TRES

RockBoard® Pedalboard	RockBoard® Professional Gig Bag Product No.
QUAD 4.1	RBO BAG 4.1 QUAD
QUAD 4.2	RBO BAG 4.2 QUAD
QUAD 4.3	RBO BAG 4.3 QUAD
QUAD 4.4	RBO BAG 4.4 QUAD
CINQUE 5.2	RBO BAG 5.2 CINQUE
CINQUE 5.3	RBO BAG 5.3 CINQUE
CINQUE 5.3 MAX	RBO BAG 5.3 CINQ MAX
CINQUE 5.4	RBO BAG 5.4 CINQUE

- 10 mm / 0.39" padding
- Padded handles
- Metal hardware
- Strong, water-resistant RokTex® outer material
- Detachable, adjustable, and padded shoulder strap
- 2-way zipper with nylon grip
- PVC (Polyvinylchloride) reinforced bottom
- 1 x sturdy front pocket for cables and accessories

RockBoard® Pedalboard	RockBoard® Flight Case Product No.
DUO 2.1	RBO CASE 2.1 DUO
DUO 2.2	RBO CASE 2.2 DUO
DUO 2.3	RBO CASE 2.3 DUO
TRES 3.0	RBO CASE 3.0 TRES
TRES 3.1	RBO CASE 3.1 TRES
TRES 3.2	RBO CASE 3.2 TRES
TRES 3.3	RBO CASE 3.3 TRES

RockBoard® Pedalboard	RockBoard® Flight Case Product No.
QUAD 4.1	RBO CASE 4.1 QUAD
QUAD 4.2	RBO CASE 4.2 QUAD
QUAD 4.3	RBO CASE 4.3 QUAD
QUAD 4.4	RBO CASE 4.4 QUAD
CINQUE 5.2	RBO CASE 5.2 CINQUE
CINQUE 5.3	RBO CASE 5.3 CINQUE
CINQUE 5.3 MAX	RBO CASE 5.3 CINQ MAX
CINQUE 5.4	RBO CASE 5.4 CINQUE

- 10 mm / 0.39" thick plywood, PVC surface with an aluminum look
- Aluminum edges
- Dense EPS foam interior lining
- Lid lined with soft foam
- 1 carry handle
- 2 lockable snap locks
- Aluminum joining rim
- 4 rubber feet

# Customize your board

## 1 Drawer (Pedalboard)



Note: Not compatible with 19" Rack Panel Single or Double (1U) - Rack Mount for RockBoard® MOD.



## 2 Slot Cover



NEW

## 1 Drawer

Rotating mounting drawer for RockBoard® pedalboards. Intelligent swivel locking mechanism for accessories, cables, wireless systems, etc. Fits MOD slots in RockBoard® pedalboards (except RockBoard® DUO 2.0, 2.1, 2.2, and 2.3). Material: reinforced polyamide. Incl. all mounting screws, counter nuts, and tools. Dimensions (W x D x H): 175 x 84.5 x 47 mm / 6.89" x 3.31" x 1.85". Weight: 150 g / 5.3 oz.

Product No.: RBO B MOD DRAWER

## 2 Slot Cover

The Slot Cover offers an elegant solution for unused slots on your pedalboard and gives the pedalboard a professional and tidy appearance by concealing empty slots and creating a harmonious look. Made of powder-coated steel, the Slot Cover is both, durable and resistant, even in demanding stage situations. For personal customization beneficial drilling templates for the common plug sockets are printed on the inside. The installation of the Slot Cover is easy and requires no special tools.

Product No.: RBO B MOD SLOT COVER

## 3 Handle Set

The ideal solution to safely and conveniently lift the pedalboard from a gig bag or flight case and to protect the neighboring pedals. These ergonomically shaped handles provide a comfortable and secure grip. They allow the pedalboard to be carried effortlessly and are made of powder-coated steel to ensure reliability and stability during transportation. Thanks to its adaptability, the Handle Set can be easily fitted to all RockBoard® models.

Product No.: RBO B HANDLE SET

## 4 QuickMount® Pedal Riser

Raises one effects pedal in standard format for better accessibility of the pedal on the upper rows of a RockBoard® pedalboard. Multiple pedal risers next to each other offer space for larger effects pedals. Easily mounted in the slot grid. Black powder-coated surface. Dimensions (L x W): 135 x 76 mm / 5.31" x 2.99". Height: 25 - 46 mm / 0.98" - 1.81" (incl. rubber feet).

Product No.: RBO B PEDAL RISER

## 5 Step Up

Gives you easier access to pedals in the upper rows of a RockBoard® pedalboard. Simply attach the RockBoard® Step Up to the preferred location on your pedalboard and attach the pedal to it. Available in three sizes.

### Step Up 1 - Narrow

Product No.: RBO STEP UP 1

### Step Up 2 - Large

Product No.: RBO STEP UP 2

### Step Up 3 - Extra Large

Product No.: RBO STEP UP 3

### Step Up Set (Narrow + Large + Extra Large)

Product No.: RBO STEP UP KIT

## 3 Handle Set

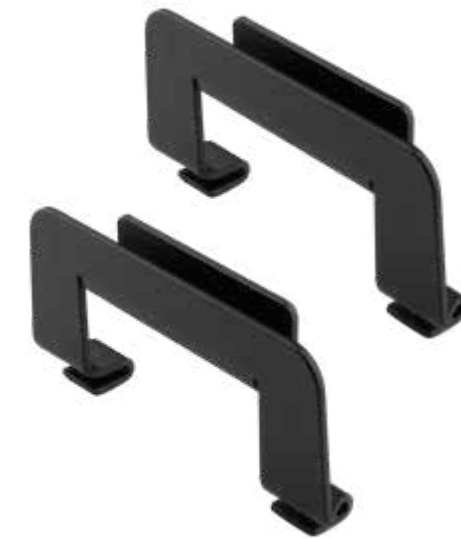

NEW

## 4 QuickMount® Pedal Riser



## 5 Step Up







**1 Base Plate**

**2 Base Plate Parts Set**

**3 Pedalboard Feet**

**4 Frame 2XL**

**5 Frame 3XL**

**6 Frame 4XL**

**7 Frame 5XL**

**8 The Tray**

**9 The Tray Rivets**

Type	Slot dimensions (W x H)	Weight
Frame 2XL	126,5 x 52 mm / 4.96" x 2.05"	75 g / 2.6 oz.
Frame 3XL	222,5 x 52 mm / 8.74" x 2.05"	140 g / 5 oz.
Frame 4XL	325 x 52 mm / 12.80" x 2.05"	220 g / 7.8 oz.
Frame 5XL	416 x 52 mm / 16.38" x 2.05"	400 g / 14.1 oz.

**1 Base Plate**

Type	Dimensions (L x W)	Weight	Product No.
TRES 3.0	431 x 227 mm / 16.97" x 8.94"	463 g / 1.02 lbs	RBO BASE PLATE 3.0
TRES 3.1	509 x 227 mm / 20.04" x 8.94"	530 g / 1.17 lbs	RBO BASE PLATE 3.1
TRES 3.2	586 x 227 mm / 23.07" x 8.94"	620 g / 1.37 lbs	RBO BASE PLATE 3.2
TRES 3.3	705 x 227 mm / 27.76" x 8.94"	714 g / 1.57 lbs	RBO BASE PLATE 3.3
QUAD 4.1	458 x 327 mm / 18.03" x 12.87"	750 g / 1.65 lbs	RBO BASE PLATE 4.1
QUAD 4.2	605 x 327 mm / 23.82" x 12.87"	890 g / 1.96 lbs	RBO BASE PLATE 4.2
QUAD 4.3	813 x 327 mm / 32.01" x 12.87"	1170 g / 2.58 lbs	RBO BASE PLATE 4.3
QUAD 4.4	706 x 323 mm / 27.80" x 12.72"	932 g / 2.05 lbs	RBO BASE PLATE 4.4
CINQUE 5.2	605 x 416 mm / 23.82" x 16.41"	1076 g / 2.37 lbs	RBO BASE PLATE 5.2
CINQUE 5.3	807 x 417 mm / 31.77" x 16.42"	1570 g / 3.46 lbs	RBO BASE PLATE 5.3
CINQUE 5.4	985 x 416 mm / 38.78" x 16.38"	1790 g / 3.95 lbs	RBO BASE PLATE 5.4
CINQUE 5.3 MAX	794 x 488 mm / 31.26" x 19.21"	1850 g / 4.08 lbs	RBO BASE PLATE 5.3MA

**1 Base Plate**

Universal mounting solution and base plate for pedalboards. Offers clean cable routing, additional space and optimal protection for power supplies, effects, cables and more. Easy mounting, no additional drilling of holes required. Made of aluminum (material thickness: 2.0 mm / 0.08"). Powder coated black surface. Incl. all mounting accessories and tools.

**2 Base Plate Parts Set**

Twist lock latch for Rockboard® Base Plate. Reusable. One set. Product No.: RBO BASE PLATE PARTS

**3 Pedalboard Feet**

Spare feet, suitable for all RockBoard® pedalboards. Set of 4. Product No.: SP RBO FOOT

**4 Frame 2XL**

Optional brace for RockBoard® Duo 2.0, 2.1, 2.2 & 2.3 pedalboards. Drop-in replacement for standard support braces. Allows the mounting of large power supplies under your RockBoard® pedalboard. Product No.: RBO B FRAME 2 XL

**5 Frame 3XL**

Optional brace for RockBoard® Tres 3.0, 3.1, 3.2 & 3.3 pedalboards. Drop-in replacement for standard support braces. Compatible with RockBoard® The Tray. Allows the mounting of large power supplies under your RockBoard® pedalboard. Product No.: RBO B FRAME 3 XL

**6 Frame 4 XL**

Optional brace for RockBoard® Quad 4.1, 4.2, 4.3 & 4.4 pedalboards. Drop-in replacement for standard support braces. Compatible with RockBoard® The Tray. Allows the mounting of even the largest power supplies under your RockBoard® pedalboard. Product No.: RBO B FRAME 4 XL

**7 Frame 5XL**

Optional brace for RockBoard® Cinque 5.2, 5.3 & 5.4 pedalboards. Drop in replacement for standard support braces. Compatible with RockBoard® The Tray. Allows the mounting of even the largest power supplies under your RockBoard® pedalboard. Product No.: RBO B FRAME 5 XL



**8 The Tray**

Universal power supply mounting solution. Fits all RockBoard® models (except Duo Series). No drilling required. Fastened with included reusable clip-mount system. Weight: 210 g / 0.46 lb. Dimensions (L x W): 241 x 122 mm / 9.49" x 4.80". Product No.: RBO B THE TRAY

**9 The Tray Rivets**

Replacement rivets for RockBoard® The Tray, reusable. Set of 5. Product No.: RBO B THE TRAY RIVET

# Keep rocking after dark

In a time of ever-growing effects rigs, visibility on stage is a major concern for many players. The RockBoard® LED Light puts an end to dimly lit pedalboards once and for all! Compatible with all RockBoard® pedalboards, the LED Light uses a simple 3-hole mounting clamp and can be attached to virtually any pedalboard to illuminate your effects rig on a dark stage. With 4 brightness settings and 6 color options, you can put your pedals in the limelight or provide subtle ambient illumination with ease.

6 colors selectable.



There when you need it.



And it disappears when it's in the way.



## RockBoard® LED Light V2 and LED Light UNI

With 4 selectable brightness levels (100% / 75% / 50% / 25%) and 6 different colors, the brightness and mood can be perfectly adapted to the environment and personal needs. 16 powerful LEDs. Power via a 9V DC adapter, 2.1 x 5.5 mm barrel plug, polarity (-) center. Current draw less than 100 mA. Dimensions (W x H x D) 220 x 220 x 25 mm / 8.66" x 8.66" x 0.98". Weight ca. 150 g / 5.3 oz.

## RockBoard® LED Light V2

The RockBoard® LED Light (V2) is a multi-colored LED lamp specially designed for use with the RockBoard® Pedalboards series. The LED Light (V2) is quickly and easily attached to the RockBoard® Pedalboard using a lockable mounting clamp. Product No.: RBO B LED LIGHT V2

## RockBoard® LED Light UNI

Equipped with a fixed universal clamp, the RockBoard® LED Light (UNI) multi-colored LED lamp can be used on a wide variety of pedalboards, music stands, mixers, tabletops and flight cases. Incl. DC female to female barrel socket adapter, 2.1 mm x 5.5 mm. Product No.: RBO B LED LIGHT UNI



Click to watch video

# More than a patchbay

## Modular Patchbays

- All-In-One Patchbay, fits perfectly into MOD slots in RockBoard® pedalboards
- Compatible with a wide variety of other pedalboards
- Acts as central access point to your effects setup
- Establishes clean cable paths within the pedalboard
- All connections mirrored on backside
- Detachable front plate for mounting on top or underneath pedalboards
- Incl. mounting screws, counter nuts and TX wrench



### 1 MOD1V2



### 2 MOD 2 V2



Click to watch video

### 1 MOD1V2

All-In-One Patchbay for pedalboards. 5 x 6.3 mm / ¼" TRS thru. 1 x XLR thru (male front / female back). 1 x DC 2.1 x 5.5 mm barrel thru. 1 x AC IEC thru (male front / female back). All connections mirrored on backside. Dimensions with front plate (W x D x H): 175 x 85 x 47 mm / 6.89" x 3.35" x 1.85". Dimensions without front plate (W x D x H): 160 x 85 x 33 mm / 6.30" x 3.35" x 1.30".

Product No.: RBO B MOD 1 V2

### 2 MOD 2 V2

All-In-One Patchbay for pedalboards. 4 x 6.3 mm / ¼" TRS thru. 2 x 5-pin DIN MIDI thru. 1 x USB Type A thru. 1 x DC 2.1 x 5.5 mm barrel thru. 1 x AC IEC thru (male front / female back). Dimensions with front plate (W x D x H): 175 x 85 x 47 mm / 6.89" x 3.35" x 1.85". Dimensions without front plate (W x D x H): 160 x 85 x 33 mm / 6.30" x 3.35" x 1.30".

Product No.: RBO B MOD 2 V2

### 3 MOD 3 V2

3 x 6.3 mm / ¼" TRS thru. 2 x XLR thru (male front / female back). 1 x XLR thru (female front / male back). 1 x DC 2.1 x 5.5 mm barrel thru. 1 x AC IEC thru (male front / female back). Dimensions with front plate (W x D x H): 175 x 85 x 47 mm / 6.89" x 3.35" x 1.85". Dimensions without front plate (W x D x H): 160 x 85 x 33 mm / 6.30" x 3.35" x 1.30".

Product No.: RBO B MOD 3 V2

### 4 MOD 4 with Transmitter

All-In-One Wireless Guitar System & Patchbay for pedalboards. Connects your instrument with your effects setup via digital wireless transmission system. 2.4 GHz ISM band for worldwide use. Range approx. 30 m / 100 ft. (without obstacles). Includes wireless transmitter unit, mounting screws and counter nuts. 4 x 6.3 mm / ¼" TRS thru. 1 x AC IEC thru (male front / female back). 1 x DC 2.1 x 5.5 mm barrel thru. 9V DC 2.1 x 5.5 mm barrel input. Dimensions with front plate (W x D x H): 175 x 85 x 47 mm / 6.89" x 3.35" x 1.85". Dimensions without front plate (W x D x H): 160 x 85 x 33 mm / 6.30" x 3.35" x 1.30".

Product No.: RBO B MOD 4 U2

### 5 MOD 5

Cabinet simulation & DI patchbay. IR based speaker cabinet simulation. 6 integrated IRs selectable. Support of additional Custom IRs (max. 1024 pts.). Integrated active DI box. Headphone amplifier. 3 x 6.3 mm / ¼" TRS thru. XLR DI Out. 6.3 mm / ¼" Parallel TRS output. 3.5 mm / 1/8" stereo headphone output with adjustable volume. Micro USB connection for firmware updates and loading custom IRs. Power supply via optional 9V DC power adapter, 2.1 x 5.5 mm barrel plug, polarity (-) center. Current Draw 300 mA. Incl. mounting screws, counter nuts and TX wrench. Dimensions with front plate (W x D x H): 175 x 85 x 47 mm / 6.89" x 3.35" x 1.85". Dimensions without front plate (W x D x H): 160 x 85 x 33 mm / 6.30" x 3.35" x 1.30".

Product No.: RBO B MOD 5

### 3 MOD 3 V2



### 4 MOD 4



### 5 MOD 5



## 1 MOD 1 Plus



## 2 MOD ISO DC 1

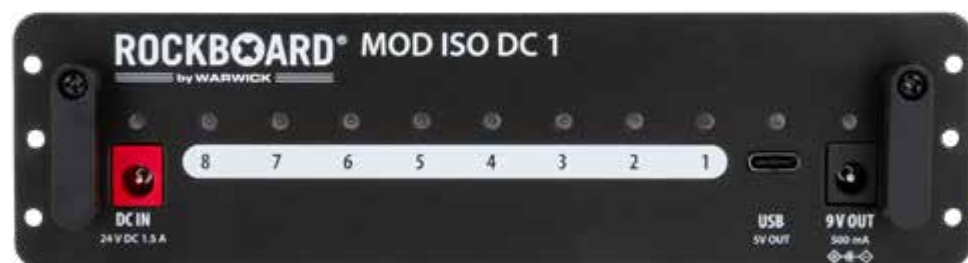

## 3 Power MOD 75



## 4 Power MOD 150



SOON

## 1 MOD 1 Plus – Buffered Isolated Patchbay

The advanced evolution of the beloved MOD 1 V2. The innovation of the MOD 1 Plus lies in its switchable buffered, isolated inputs and outputs and with the use of high-quality isolation transformers. You'll experience a crystal-clear sound that captures and reproduces every nuance of your playing. This enhanced version also features phase switches for precise tonal adjustments, ensuring you achieve the perfect sound quality every time.

Product No.: RBO B MOD 1 PLUS

## 2 MOD ISO DC 1 –

### Isolated Multi Power Supply MOD

The ISO DC 1 is a multi-power supply for effect pedals that provides 8x electrically isolated, highly filtered power connections (9V/300mA) and a 5V USB-C connection. The set includes a 1x 24V DC power adapter (1.500 mA) with exchangeable multi-regional plug adapters (EU, UK, US/CA, AU/NZ) and 8x RockBoard® Flat Power Cable, 60 cm (for connecting effects pedals).

Product No.: RBO B MOD ISO DC 1

## 3 Power MOD 75 -

### Compact Pedalboard Power Amp

The Power MOD 75 is a specially developed Class D transistor power amplifier that can drive speaker cabinets directly from the pedalboard without additional amplifiers. 75 watts, a switchable cab sim, headphone and DI out, mute switch and a 3-band EQ make this device a versatile little helper with a wide range of applications.

Product No.: RBO B MOD PW 75

## 4 Power MOD 150 -

### Compact Pedalboard Power Amp

The Power MOD 150, the "Big Brother" of the Power MOD 75, is a specially developed Class D transistor power amplifier that can drive speaker cabinets directly from the pedalboard without additional amplifiers. 150 watts, a switchable cab sim, headphone and DI out, mute switch and a 3-band EQ make this device a versatile little helper with a wide range of applications.

Product No.: RBO B MOD PW 150

## 5 Mini MOD DC

The RockBoard® Mini MOD DC is a simple DC patchbay for the RockBoard® pedalboards. Perfectly fitting the mounting holes of the LED Light on all pedalboards, it offers convenient access to the power supply setup without having to route the power supply cable under the pedalboard. The pedals can be permanently connected to a multi power supply and provide a convenient and easily accessible power supply to the board through the central DC 2.1 x 5.5 mm barrel thru access point. 1 x DC 2.1 x 5.5 mm female connector to 2 x DC 2.1 x 5.5 mm female connector (parallel). Dimensions (W x H x D): 70 x 35 x 20-25 mm / 2.75" x 1.38" x 0.79-0.98". Weight 30 g / 1 oz. Incl. 3 mounting screws.

Product No.: RBO B MOD MINI DC

## 5 Mini MOD DC

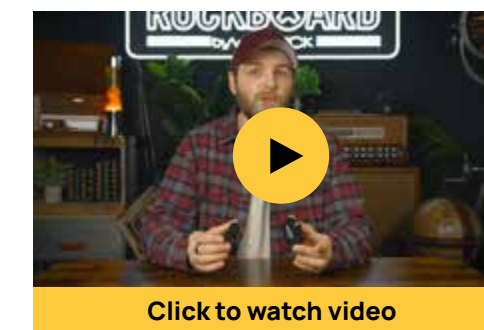

## 6 Mini MOD TRS

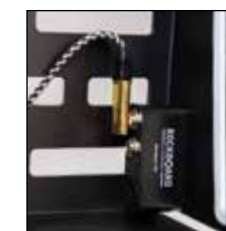

## 6 Mini MOD TRS

The RockBoard® Mini MOD TRS is a simple patchbay for the RockBoard® pedalboard series. Perfectly fitting the LED Light mounting holes on all pedalboards, it provides a central access point from the instrument to the pedalboard or from the pedalboard to the amp. With the RockBoard® Mini MOD TRS, you can permanently connect your pedals under the board and conveniently organize

all connections to and from your effects setup. The use of TRS jacks can make for very easy send/return applications. 1 x 6.3 mm TRS stereo jack to 2 x 6.3 mm TRS stereo jack. Send/return application can be realized with Y-split cable (not included). Dimensions (W x H x D): 70 x 35 x 20-25 mm / 2.75" x 1.38" x 0.79-0.98". Weight 50 g / 1.76 oz. Incl. 3 mounting screws. Product No.: RBO B MOD MINI TRS

**1 19" Rack Panel Single (1U)\***



**2 19" Rack Panel Double (1U)\***



Click to watch video

**3 MOD Rack**



**4 MOD Brace**

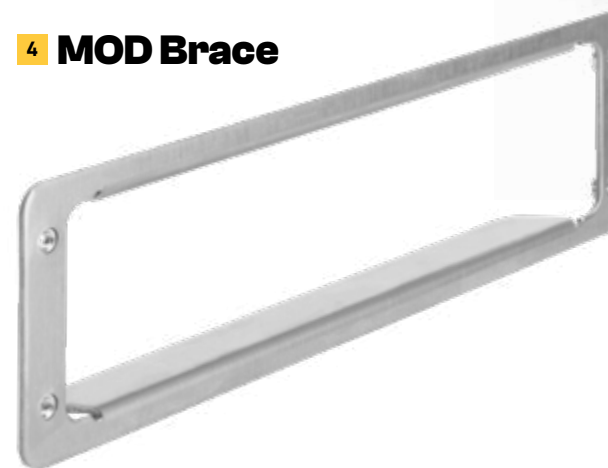

**5 Screws**



**1 19" Rack Panel Single (1U)\***

Mounting slot for one RockBoard® MOD into a standard 19" rack (Not compatible with MOD1, 2, 3 V1). Black powder-coated steel panel. Height: 1U. Width: 19". Material thickness: 2.0 mm / 0.08". Weight: 430 g / 15.2 oz.  
Product No.: RBO B RACK PANEL 1

Width: 19". Material thickness: 2.0 mm / 0.08". Weight: 392 g / 13.8 oz.  
Product No.: RBO B RACK PANEL 2

**3 MOD Rack**

Module support rack for pedalboards. Allows horizontal and vertical mounting of MOD V2 on pedalboards from other brands. Mounting height of MOD V2 adjustable. Omni-directional. Incl. all mounting screws and counter nuts.  
Product No.: RBO B MOD RACK

**4 MOD Brace**

Metal brace for RockBoard® MODs. Secures your RockBoard® MOD on the RockBoard® pedalboard. Made of stainless steel. Mounting hole distance (W x H): 168 x 28 mm / 6.61" x 1.10". Incl. mounting screws and wrench. Dimensions (W x D x H): 179 x 17 x 48 mm / 7.05" x 0.67" x 1.89".  
Product No.: RBO B MOD BRACE

**5 Screws - Set of 2**

Replacement screws for RockBoard® MOD patchbays. M3 x 10 mm threads. TX10 drive. Incl. counter nuts.  
Product No.: RBO B MOD SCREWS

# Always your sound



Click to watch video

## Specs for RockBoard® HA 1

- Compact and lightweight design
- Practical, externally accessible battery compartment with clip lock
- Solid belt clip for fixing to belt or waistband
- Up to 12 hours of battery life (using AAA alkaline batteries)
- Volume/on-off control
- Mono/Stereo source switch, easily accessible
- Status LED  
BLUE = high power, PINK = low power, RED = change batteries
- Aluminum housing
- 1 x combo jack stereo (6.35 mm) / XLR input
- 1 x 3.5 mm stereo jack headphone output
- Max. output:  
2 x 110 mW at 16 Ohm
- Impedance <0.1 Ohm
- Power supply via 2 x AAA batteries (not included)
- Dimensions (L x W x H) incl. clip, jack & knob:  
141 x 30 x 36 mm / 5.55" x 1.18" x 1.42"
- Weight: 97 g / 3.4 oz. (without batteries)



### 1 HA 1 In-Ear Monitoring Headphone Amplifier

**1 HA 1 In-Ear Monitoring Headphone Amplifier**  
The ideal partner for singers, keyboardists, drummers, guitarists, bassists and other musicians. It establishes the connection between the monitoring signal from the mixing console, instrument or amp and your own headphones. Operation is easy: Simply activate the unit with the volume control and adjust the desired volume for the headphone signal. With the mono/stereo source switch, easily accessible on the

unit, the RockBoard® HA 1 can be adjusted to the respective input signal. The HA 1 has a status LED that changes color depending on the available battery voltage. Two AAA batteries provide up to 12 hours of power, and changing the batteries is quick and easy, thanks to the practical battery compartment with clip lock, which can be easily reached from the outside. The HA 1 is equipped with a combination jack for use with stereo jack (6.35 mm) and XLR cables for the

input signal and a 3.5 mm stereo jack headphone output. On stage, in the rehearsal room or at home, the RockBoard® HA 1 in-ear monitoring headphone amplifier always offers full control over the monitoring signal. In small clubs, in-ear monitoring improves the acoustics in the hall; if the band turns up the volume again, the signal is quickly adjusted and you can enjoy the same sound in every part of the room.  
Product No.: RBO E HA 1

### 2 HA 2 In-Ear Monitoring Controller



### 3 HA 3 In-Ear Monitoring Headphone Amplifier

#### 2 HA 2 In-Ear Monitoring Controller

The HA 2 is a compact, portable passive volume control for headphones. It is a great tool whenever the volume of headphone signals from in-ear or headband headphones needs to be adjusted. It features a robust metal housing and a metal output socket that is secured with a locking ring. This makes the HA 2 perfect for stage performances or in a rehearsal room. As it is passive, it does not require any batteries.  
Product No.: RBO E HA 2

#### 3 HA 3 In-Ear Monitoring Headphone Amplifier

The more comfortable version of the HA 1 with a "MORE ME" option. The balance control adjusts the amount of the two switchable mono or stereo signal inputs and the volume control adjusts the overall volume of the two signals. The ideal partner for singers, keyboardists, drummers, guitarists, bassists, and other musicians who need the connection between the monitoring signal from the mixing console, instrument or amp and your own headphones.  
Product No.: RBO E HA 3



SOON

# Secure them all

Innovation vs. Velcro® - Introducing the RockBoard® QuickMount® System! Are you tired of sticky hook & loop tape that collects dust and other debris? Has adhesive tape ever ripped off your pedal's serial number or warranty sticker? Then look no further! The RockBoard® QuickMount® mounting plates are the solution. Available for a wide variety of pedal shapes.



Click to watch video

Simply screw a QuickMount® onto each of your pedals using the screws from their back plates (longer screws are also included) and click them into the slot grid on the surface of your RockBoard®. Removal is also easy thanks to the QuickRelease Tool.

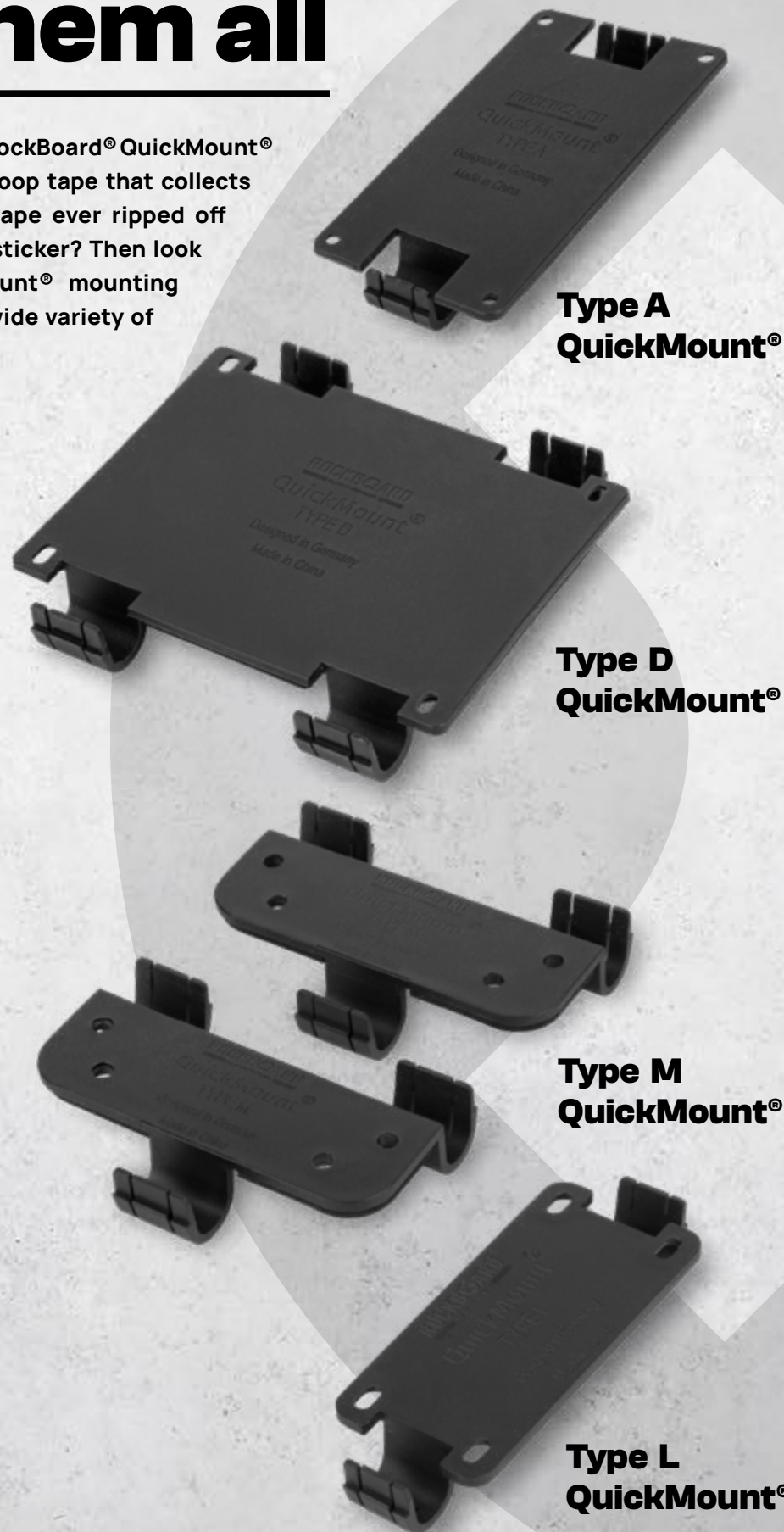

**Type A QuickMount®**

**Type D QuickMount®**

**Type M QuickMount®**

**Type L QuickMount®**

## 1 Cable Fix - Cable Clips

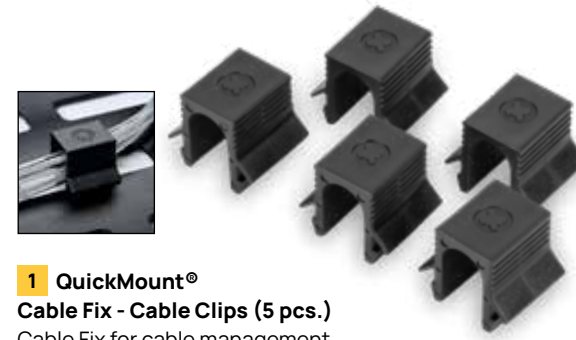

**1 QuickMount® Cable Fix - Cable Clips (5 pcs.)**  
Cable Fix for cable management.  
Product No.: RBO B QM AC CF

**2 QuickMount® Pick Box**  
PickBox Accessory Case.  
Product No.: RBO B QM AC PB

**3 QuickMount® QuickRelease Tool**  
Product No.: RBO B QM AC QR

## 2 Pick Box



## 3 QuickRelease Tool

QuickMount® Type	Compatible with	Product No.
Type A	MXR® standard size and Electro Harmonix® nano series	RBO B QM T A
Type B1	Friedman® standard size, Wampler® EQ / Velvet Fuzz and Walrus Deep Six / Julia V2 / 385 Overdrive / Jupiter V2	RBO B QM T B1
Type C	EarthQuaker Devices®, Electro Harmonix®, Keeley Electronics®, MXR®, JHS® Pedals, Darkglass Electronics® and many other effects pedals with larger vertical housings	RBO B QM T C
Type D	Electro Harmonix®, Keeley Electronics®, MXR® and many other effects pedals with larger horizontal housings and the Warwick® Gnome amp	RBO B QM T D
Type E	Standard size BOSS® compact series	RBO B QM T E
Type F	Standard size Ibanez® Tube Screamer and Maxon® Nine series	RBO B QM T F
TYPE FT1	Fulltone® OCD / 69 MK2	RBO B QM T FT1
TYPE FT2	Fulltone® CS-Ranger / Full-Drive 1 / Mas Malo / Queen Bee	RBO B QM T FT2
TYPE FT3	Fulltone® Supa-Trem / Full-Drive 2	RBO B QM T FT3
TYPE FT4	Fulltone® Deja Vibe	RBO B QM T FT4
TYPE FT5	Fulltone® Full-Drive 3	RBO B QM T FT5
Type G	TC Electronic® standard size	RBO B QM T G
Type H	DigiTech® compact series	RBO B QM T H
Type I	Eventide® H9 effects pedal	RBO B QM T I
Type J	Medium-sized Strymon® effects pedals	RBO B QM T J
TYPE J1	Boss® DD-500 / MD-500 / RC-500 / RV-500 and Strymon® Big Sky / Mobius / Timeline	RBO B QM T J1

QuickMount® Type	Compatible with	Product No.
TYPE J2	Strymon® Nightsky / Volante	RBO B QM T J2
Type K	Mooer® micro series effects pedals	RBO B QM T K
Type L	MXR®, Pigtronix®, Xotic®, XVive® and many other effects pedals with mini-style housings	RBO B QM T L
TYPE L6	Line6® HX Stomp	RBO B QM T L6
TYPE LE1	Lehle® Sunday Driver II / P-Split III	RBO B QM T LE1
TYPE LE2	Lehle® Little Lehle III / Sunday Driver SW II	RBO B QM T LE2
TYPE LE3	Lehle® Parallel SW II / Little Dual	RBO B QM T LE3
TYPE LE4	Lehle® Dual / D.Loop / 3@1 / 1@3	RBO B QM T LE4
Type M	Dunlop® Cry Baby standard size wah pedals and the RockBoard® StageTuner ST-02	RBO B QM T M
TYPE MR	Meris® Pedals (Hedra)	RBO B QM T MR
TYPE N	TC-Helicon® Harmony Singer 2 / Duplicator / Mic Mechanic 2	RBO B QM T N
TYPE O	Friedman® Overdrive Deluxe / Walrus® Descent	RBO B QM T O
TYPE SR1	Source Audio® AfterShock / Vertigo / EQ / True Spring Reverb / Gemini Chorus / C4 Synth	RBO B QM T SR1
TYPE SR2	Source Audio® Ventris Dual Reverb / 263 Collider / Nemesis Delay	RBO B QM T SR2
Type UH	Effects pedals with horizontal design Mounting hole distance (D x W): 51 x 103 mm / 29 mm x 73 - 91 mm	RBO B QM T UH
Type UV	Effects pedals with vertical design Dimensions: 96 x 48 mm	RBO B QM T UV
TYPE WH1	Way Huge® Smalls series	RBO B QM T WH1
TYPE WH2	Way Huge® Green Rhino / Swollen Pickle	RBO B QM T WH2
TYPE WH3	Way Huge® Supa-Puss	RBO B QM T WH3

**1 Type A**



**2 Type B1**



**3 Type C**



**10 Type FT4**



**11 Type FT5**



**12 Type G**



**4 Type D**



**5 Type E**



**6 Type F**



**13 Type H**



**14 Type I**

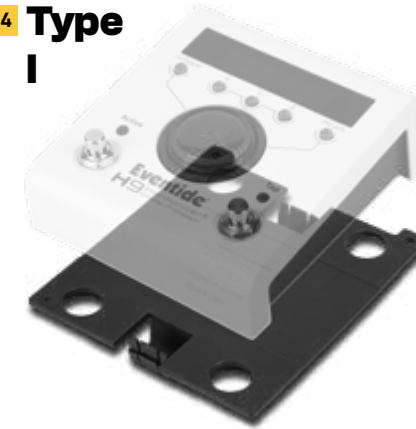

**15 Type J**



**7 Type FT1**



**8 Type FT2**



**9 Type FT3**



**16 Type J1**



**17 Type J2**



**18 Type K**



**1 QuickMount® Type A**  
Compatible with MXR® standard size / Electro Harmonix® nano series.  
Product No.: RBO B QM T A

**2 QuickMount® Type B1**  
Compatible with Friedman® standard size, Wampler® EQ / Velvet Fuzz and Walrus Deep Six / Julia V2 / 385 Overdrive / Jupiter V2.  
Product No.: RBO B QM T B1

**3 QuickMount® Type C**  
Compatible with EarthQuaker Devices®, Electro Harmonix®, Keeley Electronics®, MXR®, JHS®

Pedals, Darkglass Electronics® and many other effects pedals with larger vertical housings.  
Product No.: RBO B QM T C

**4 QuickMount® Type D**  
Compatible with Electro Harmonix®, Keeley Electronics®, MXR® and many other effects pedals with larger horizontal housings and the Warwick® Gnome amp.  
Product No.: RBO B QM T D

**5 QuickMount® Type E**  
Compatible with standard size BOSS® compact series.  
Product No.: RBO B QM T E

**6 QuickMount® Type F**  
Compatible with Standard size Ibanez® Tube Screamer / Maxon® Nine series.  
Product No.: RBO B QM T F

**7 QuickMount® Type FT1**  
Compatible with Fulltone® OCD / 69 MK2.  
Product No.: RBO B QM T FT1

**8 QuickMount® Type FT2**  
Compatible with Fulltone® CS-Ranger / Full-Drive 1 / Mas Malo / Queen Bee.  
Product No.: RBO B QM T FT2

**9 QuickMount® Type FT3**  
Compatible with Fulltone® Supa-Trem / Full-Drive 2.  
Product No.: RBO B QM T FT3

**10 QuickMount® Type FT4**  
Compatible with Fulltone® Deja Vibe.  
Product No.: RBO B QM T FT4

**11 QuickMount® Type FT5**  
Compatible with Fulltone® Full-Drive 3.  
Product No.: RBO B QM T FT5

**12 QuickMount® Type G**  
Compatible with TC Electronic® standard size.  
Product No.: RBO B QM T G

**13 QuickMount® Type H**  
Compatible with DigiTech® compact series.  
Product No.: RBO B QM T H

**14 QuickMount® Type I**  
Compatible with Eventide® H9 effects pedal.  
Product No.: RBO B QM T I

**15 QuickMount® Type J**  
Compatible with Medium-sized Strymon® effects pedals.  
Product No.: RBO B QM T J

**16 QuickMount® Type J1**  
Compatible with Boss® DD-500 / MD-500 / RC-500 / RV-500 and Strymon® Big Sky / Mobius / Timeline.  
Product No.: RBO B QM T J1

**17 QuickMount® Type J2**  
Compatible with Strymon® Nightsky / Volante.  
Product No.: RBO B QM T J2

**18 QuickMount® Type K**  
Compatible with Moer® micro series effects pedals.  
Product No.: RBO B QM T K



**1 Type L**



**2 Type L6**



**3 Type LE1**



**10 Type O**



**11 Type SR1**



**12 Type SR2**



**4 Type LE2**



**5 Type LE3**



**6 Type LE4**



**13 Type UH**



**14 Type UV**



**15 Type WH1**



**7 Type M**



**8 Type MR**



**9 Type N**



**16 Type WH2**



**17 Type WH3**



**18 Pick Box**



**1 QuickMount® Type L**  
Compatible with MXR® / Pigtronix® / Xotic® / XVive® and many other effects pedals with mini-style housings.  
Product No.: RBO B QM T L

**2 QuickMount® Type L6**  
Compatible with Line6® HX Stomp.  
Product No.: RBO B QM T L6

**3 QuickMount® Type LE1**  
Compatible with Lehle® Sunday Driver II / P-Split III.  
Product No.: RBO B QM T LE1

**4 QuickMount® Type LE2**  
Compatible with Lehle® Little Lehle III / Sunday Driver SW II.  
Product No.: RBO B QM T LE2

**5 QuickMount® Type LE3**  
Compatible with Lehle® Parallel SW II / Little Dual.  
Product No.: RBO B QM T LE3

**6 QuickMount® Type LE4**  
Compatible with Lehle® Dual / D.Loop / 3@1 / 1@3.  
Product No.: RBO B QM T LE4

**7 QuickMount® Type M**  
Compatible with Dunlop® Cry Baby standard size wah pedals / RockBoard® StageTuner ST-02.  
Product No.: RBO B QM T M

**8 QuickMount® Type MR**  
Compatible with Meris® Pedals (Hedra).  
Product No.: RBO B QM T MR

**9 QuickMount® Type N**  
Compatible with TC-Helicon® Harmony Singer 2 / Duplicator / Mic Mechanic 2.  
Product No.: RBO B QM T N

**10 QuickMount® Type O**  
Compatible with Friedman® Overdrive Deluxe / Walrus® Descent.  
Product No.: RBO B QM T O

**11 QuickMount® Type SR1**  
Compatible with Source Audio® AfterShock / Vertigo / EQ / True Spring Reverb / Gemini Chorus / C4 Synth.  
Product No.: RBO B QM T SR1

**12 QuickMount® Type SR2**  
Compatible with Source Audio® Ventris Dual Reverb / 263 Collider / Nemesis Delay.  
Product No.: RBO B QM T SR2

**13 QuickMount® Type UH**  
Compatible with Effects pedals with horizontal design. Mounting hole distance (D x W): 51 x 103 mm / 29 mm x 73 - 91 mm / 2.01" x 4.06" / 1.14" x 2.87" - 3.58".  
Product No.: RBO B QM T UH

**14 QuickMount® Type UV**  
Compatible with Effects pedals with vertical design. Dimensions: 96 x 48 mm / 3.78" x 1.89".  
Product No.:

**15 QuickMount® Type WH1**  
Compatible with Way Huge® Smalls series.  
Product No.: RBO B QM T WH1

**16 QuickMount® Type WH2**  
Compatible with Way Huge® Green Rhino / Swollen Pickle.  
Product No.: RBO B QM T WH2

**17 QuickMount® Type WH3**  
Compatible with Way Huge® Supa-Puss.  
Product No.: RBO B QM T WH3

**18 QuickMount® Pick Box**  
PickBox Accessory Case.  
Product No.: RBO B QM AC PB

# Protect your investment

A RockBoard® PedalSafe® is a protective transparent rubber pedal cover that comes with detachable caps so you can easily access to pedals controls. They safeguard your pedals and keep them in pristine condition. No dirt, beer, dust, sweat or rain will get through while you are rocking!

The PedalSafe® covers clamp onto mounting plates, which can then be fixed to any pedalboard using screws or hook & loop tape - so you do not have to stick any adhesive onto the pedals themselves. Additionally, the RockBoard® PedalSafe® covers are compatible with our QuickMount® system. Each PedalSafe® is also available with a corresponding QuickMount® mounting plate for use with RockBoard® pedalboards.



**PedalSafe® Set Type A1 with RockBoard® QuickMount® mounting plates.**



**PedalSafe® Set Type A1 with Universal Mounting Plates for ordinary boards.**



Pedal-Safe® Type	Compatible with	QuickMount® Mounting Plates Product No.	Universal Mounting Plates Product No.
Pick Box	Universal Pick Box with silicone pad	RBO B QM T PB	RBO B PS AC PB
TYPE A1.1	MXR® standard size pedals and Dunlop® Echoplex Delay	RBO B PS T A1.1 RBO	RBO B PS T A1.1 UNI
Type A2	Electro Harmonix® nano series and MXR® standard size pedals with 2 input and 2 output jacks	RBO B PS T A2 RBO	RBO B PS T A2 UNI
TYPE B1	Friedman® standard size, Wampler® EQ / Velvet Fuzz and Walrus® Deep Six / Julia V2 / 385 OD / Jupiter V2	RBO B PS T B1 RBO	RBO B PS T B1 UNI
TYPE B2	Walrus® ARP-87 / Monument® V2	RBO B PS T B2 RBO	RBO B PS T B2 UNI
TYPE B3	Walrus® Mako D1	RBO B PS T B3 RBO	RBO B PS T B3 UNI
Type C	EarthQuaker Devices®, Electro Harmonix®, Keeley Electronics®, MXR®, JHS® Pedals, Darkglass Electronics® and many other effects pedals with similar larger vertical housings	RBO B PS T C RBO	RBO B PS T C UNI
TYPE C2	Walrus® EB-10 and Wampler® Tape Echo / Plexi-Drive	RBO B PS T C2 RBO	RBO B PS T C2 UNI
Type D1	Electro Harmonix®, Keeley Electronics®, MXR® and many other effects pedals with similar larger horizontal housings and a one-row knob configuration	RBO B PS T D1 RBO	RBO B PS T D1 UNI
Type D2	Electro Harmonix®, Keeley Electronics®, MXR® and many other effects pedals with similar larger horizontal housings and a two-row knob configuration	RBO B PS T D2 RBO	RBO B PS T D2 UNI
TYPE D3	Wampler® Paisley Deluxe / Hot Wired / Dual Fusion	RBO B PS T D3 RBO	RBO B PS T D3 UNI
TYPE E1	Standard size Boss® compact series effects pedals and RC3/5 Loop Station	RBO B PS T E1 RBO	RBO B PS T E1 UNI
Type F	Standard size Ibanez® Tube Screamer and Maxon® Nine series effects pedals	RBO B PS T F RBO	RBO B PS T F UNI
TYPE FT1	Fulltone® OCD / 69 MK2	RBO B PS T FT1 RBO	RBO B PS T FT1 UNI
TYPE FT2	Fulltone® CS-Ranger / Full-Drive 1 / Mas Malo / Queen Bee	RBO B PS T FT2 RBO	RBO B PS T FT2 UNI
TYPE FT3.1	Fulltone® Supa-Trem	RBO B PS T FT3.1 RBO	RBO B PS T FT3.1 UNI
TYPE FT3.2	Fulltone® Full-Drive 2	RBO B PS T FT3.2 RBO	RBO B PS T FT3.2 UNI
TYPE FT4	Fulltone® Deja Vibe	RBO B PS T FT4 RBO	RBO B PS T FT4 UNI
TYPE FT5	Fulltone® Full-Drive 3	RBO B PS T FT5 RBO	RBO B PS T FT5 UNI

Pedal-Safe® Type	Compatible with	QuickMount® Mounting Plates Product No.	Universal Mounting Plates Product No.
Type G	Standard size TC Electronic® effects pedals with side mounted jacks	RBO B PS T G RBO	RBO B PS T G UNI
Type H	DigiTech® Compact Series effects pedals	RBO B PS T H RBO	RBO B PS T H UNI
Type I	Eventide® H9 effects pedals	RBO B PS T I RBO	RBO B PS T I UNI
Type J	Medium-sized Strymon® effects pedals	RBO B PS T J RBO	RBO B PS T J UNI
TYPE J1.1	Boss® DD-500 / MD-500 / RC-500 / RV-500	RBO B PS T J1.1 RBO	RBO B PS T J1.1 UNI
TYPE J1.2	Strymon® Big Sky / Mobius / Timeline	RBO B PS T J1.2 RBO	RBO B PS T J1.2 UNI
TYPE J2	Strymon® Nightsky / Volante	RBO B PS T J2 RBO	RBO B PS T J2 UNI
Type K1	Mooer® micro series effects pedals with a large knob configuration	RBO B PS T K1 RBO	RBO B PS T K1 UNI
Type K2	Mooer® micro series effects pedals with multiple small knobs or large display configuration (Micro Preamp Series, New Micro Series, Radar)	RBO B PS T K2 RBO	RBO B PS T K2 UNI
Type L	MXR®, Pigtronix®, Xotic®, XVive® and many other effects pedals with mini-sized housings	RBO B PS T L RBO	RBO B PS T L UNI
TYPE L6	Line6® HX Stomp	RBO B PS T L6 RBO	RBO B PS T L6 UNI
TYPE LE1	Lehle® Sunday Driver II / P-Split III	RBO B PS T LE1 RBO	RBO B PS T LE1 UNI
TYPE LE2	Lehle® Little Lehle III / Sunday Driver SW II	RBO B PS T LE2 RBO	RBO B PS T LE2 UNI
TYPE LE3	Lehle® Parallel SW II / Little Dual	RBO B PS T LE3 RBO	RBO B PS T LE3 UNI
TYPE LE4	Lehle® Dual / D.Loop / 3@1 / 1@3	RBO B PS T LE4 RBO	RBO B PS T LE4 UNI
TYPE MR	Meris® Pedals (Hedra)	RBO B PS T MR RBO	RBO B PS T MR UNI
TYPE N	TC-Helicon® Harmony Singer 2 / Duplicator / Mic Mechanic 2	RBO B PS T N RBO	RBO B PS T N UNI
TYPE O	Friedman® Overdrive Deluxe / Walrus® Descent	RBO B PS T O RBO	RBO B PS T O UNI
TYPE SR1	Source Audio® AfterShock / Vertigo / EQ / True Spring Reverb / Gemini Chorus / C4 Synth	RBO B PS T SR1 RBO	RBO B PS T SR1 UNI
TYPE SR2	Source Audio® Ventris Dual Reverb / 263 Collider / Nemesis Delay	RBO B PS T SR2 RBO	RBO B PS T SR2 UNI
TYPE WH1	Way Huge® Smalls series	RBO B PS T WH1 RBO	RBO B PS T WH1 UNI
TYPE WH2	Way Huge® Green Rhino / Swollen Pickle	RBO B PS T WH2 RBO	RBO B PS T WH2 UNI
TYPE WH3	Way Huge® Supa-Puss	RBO B PS T WH3 RBO	RBO B PS T WH3 UNI

# Keep your effects pedals safe



Click to watch video

Secure your pedal's settings against unintentional adjustments.

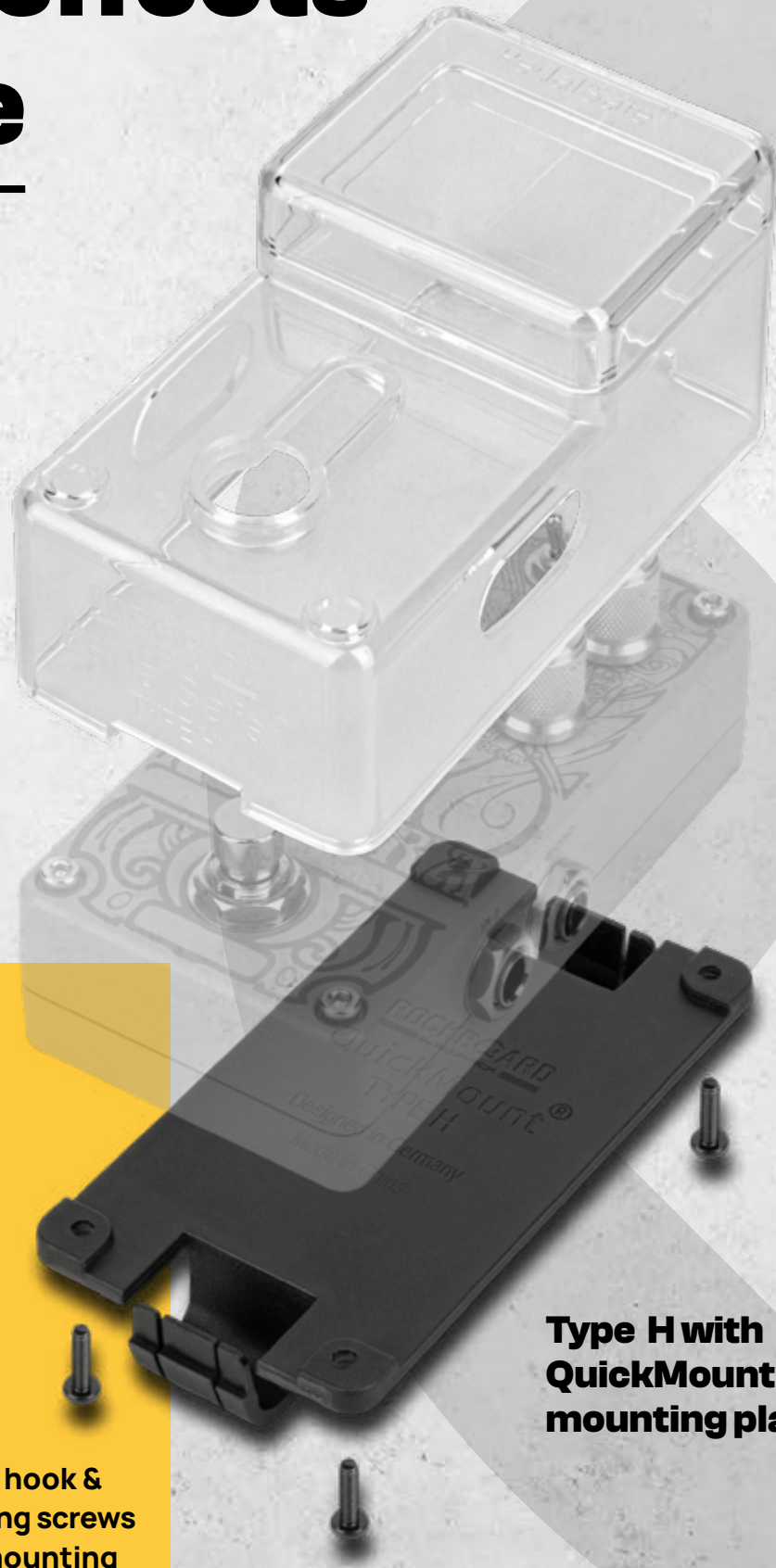

**Type H with QuickMount® mounting plate**

## Specs for RockBoard® PedalSafe®

- Protective plastic cover that fits most popular effects pedals
- Protects your effects pedals from liquids, dirt and weather
- Prevents accidental knob adjustments
- Does not require modifying your effects pedals
- Includes a base plate for mounting on any pedalboard using screws or hook & loop tape. Incl. replacement mounting screws
- Also available with QuickMount® mounting plates for RockBoard® pedalboards

### 1 Type A1.1



### 4 Type B2

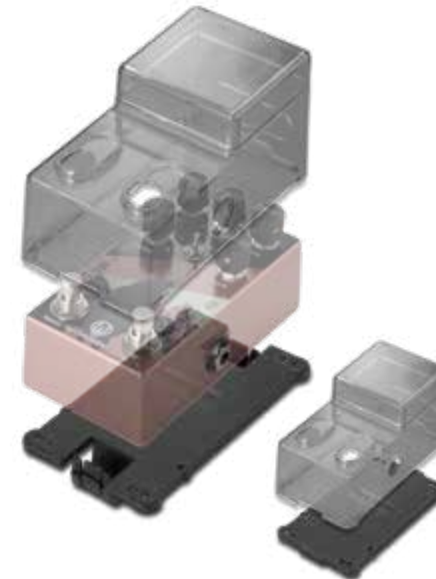

### 2 Type A2



### 5 Type B3



### 3 Type B1



### 6 Type C



#### 1 PedalSafe® Type A1.1

Compatible with MXR® standard size pedals / Dunlop® Echoplex Delay.

**With QuickMount® mounting plate**

Product No.: RBO B PS T A1.1 RBO

**With universal mounting plate**

Product No.: RBO B PS T A1.1 UNI

#### 2 PedalSafe® Type A2

Compatible with Electro Harmonix® nano series / MXR® standard size pedals with 2 input and 2 output jacks.

**With QuickMount® mounting plate**

Product No.: RBO B PS T A2 RBO

**With universal mounting plate**

Product No.: RBO B PS T A2 UNI

#### 3 PedalSafe® Type B1

Compatible with Friedman® standard size, Wampler® EQ / Velvet Fuzz and Walrus® Deep Six / Julia V2 / 385 OD / Jupiter V2.

**With QuickMount® mounting plate**

Product No.: RBO B PS T B1 RBO

**With universal mounting plate**

Product No.: RBO B PS T B1 UNI

#### 4 PedalSafe® Type B2

Compatible with Walrus® ARP-87 / Monument V2.

**With QuickMount® mounting plate**

Product No.: RBO B PS T B2 RBO

**With universal mounting plate**

Product No.: RBO B PS T B2 UNI

#### 5 PedalSafe® Type B3

Compatible with Walrus® Mako D1.

**With QuickMount® mounting plate**

Product No.: RBO B PS T B3 RBO

**With universal mounting plate**

Product No.: RBO B PS T B3 UNI

#### 6 PedalSafe® Type C

Compatible with EarthQuaker Devices® / Eléctro Harmonix® / Keeley Electronics® / MXR® / JHS® Pedals / Darkglass Electronics® / Many other effects pedals with similar larger vertical housings.

**With QuickMount® mounting plate**

Product No.: RBO B PS T C RBO

**With universal mounting plate**

Product No.: RBO B PS T C UNI

## 1 Type C2



## 2 Type D1



## 3 Type D2



## 4 Type D3



## 5 Type E1

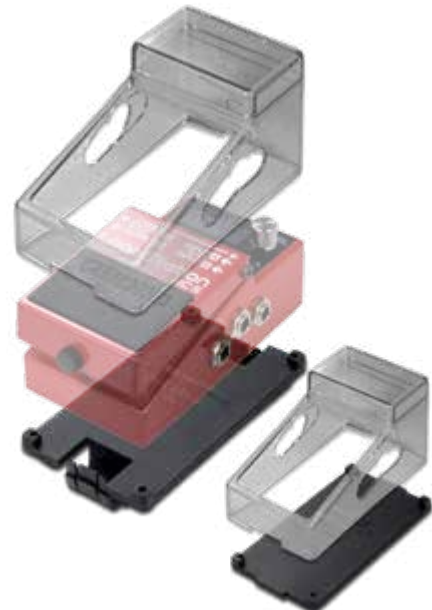

## 6 Type F

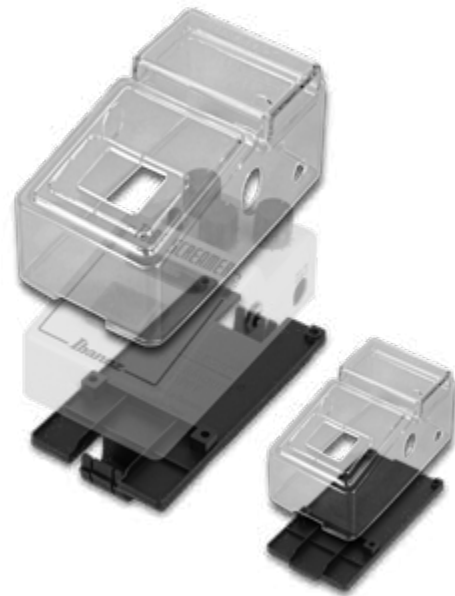

## 7 Type FT1

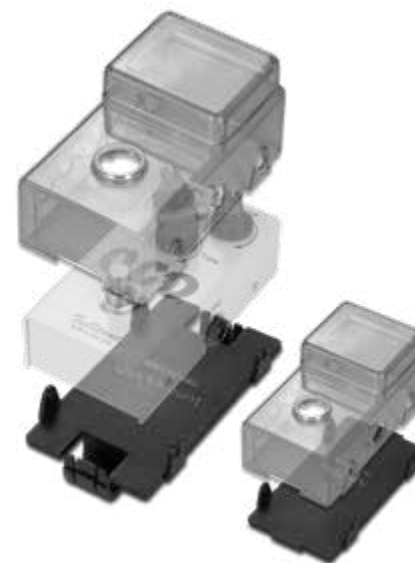

## 8 Type FT2



## 9 Type FT3.1



## 10 Type FT3.2

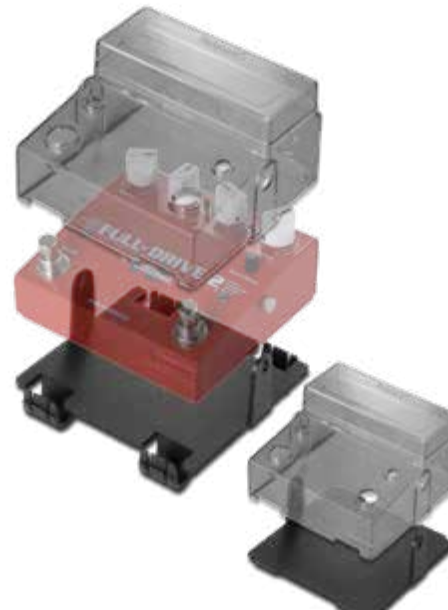

## 11 Type FT4

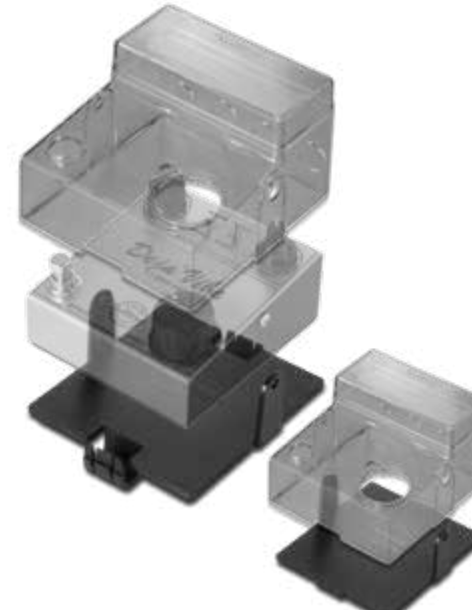

## 12 Type FT5



### 1 PedalSafe® Type C2

Compatible with Walrus® EB-10 and Wampler® Tape Echo / Plexi-Drive.

**With QuickMount® mounting plate**

Product No.: RBO B PS T C2 RBO

**With universal mounting plate**

Product No.: RBO B PS T C2 UNI

### 2 PedalSafe® Type D1

Compatible with ElectroHarmonix® / Keeley Electronics® / MXR® and many other effects pedals with similar larger horizontal housings and a one-row knob configuration.

**With QuickMount® mounting plate**

Product No.: RBO B PS T D1 RBO

**With universal mounting plate**

Product No.: RBO B PS T D1 UNI

### 3 PedalSafe® Type D2

Compatible with ElectroHarmonix® / Keeley Electronics® / MXR® and many other effects pedals with similar larger horizontal housings and a two-row knob configuration.

**With QuickMount® mounting plate**

Product No.: RBO B PS T D2 RBO

**With universal mounting plate**

Product No.: RBO B PS T D2 UNI

### 4 PedalSafe® Type D3

Compatible with Wampler® Paisley Deluxe / Hot Wired / Dual Fusion.

**With QuickMount® mounting plate**

Product No.: RBO B PS T D3 RBO

**With universal mounting plate**

Product No.: RBO B PS T D3 UNI

### 5 PedalSafe® Type E1

Compatible with Standard size Boss® compact series effects pedals and RC3/5 Loop Station.

**With QuickMount® mounting plate**

Product No.: RBO B PS T E1 RBO

**With universal mounting plate**

Product No.: RBO B PS T E1 UNI

### 6 PedalSafe® Type F

Compatible with Standard size Ibanez® Tube Screamer / Maxon® Nine series effects pedals.

**With QuickMount® mounting plate**

Product No.: RBO B PS T F RBO

**With universal mounting plate**

Product No.: RBO B PS T F UNI

### 7 PedalSafe® Type FT1

Compatible with Fulltone® OCD / 69 MK2.

**With QuickMount® mounting plate**

Product No.: RBO B PS T FT1 RBO

**With universal mounting plate**

Product No.: RBO B PS T FT1 UNI

### 8 PedalSafe® Type FT2

Compatible with Fulltone® CS-Ranger / Full-Drive 1 / Mas Malo / Queen Bee.

**With QuickMount® mounting plate**

Product No.: RBO B PS T FT2 RBO

**With universal mounting plate**

Product No.: RBO B PS T FT2 UNI

### 9 PedalSafe® Type FT3.1

Compatible with Fulltone® Supa-Trem.

**With QuickMount® mounting plate**

Product No.: RBO B PS T FT3.1 RBO

**With universal mounting plate**

Product No.: RBO B PS T FT3.1 UNI

### 10 PedalSafe® Type FT3.2

Compatible with Fulltone® Full-Drive 2.

**With QuickMount® mounting plate**

Product No.: RBO B PS T FT3.2 RBO

**With universal mounting plate**

Product No.: RBO B PS T FT3.2 UNI

### 11 PedalSafe® Type FT4

Compatible with Fulltone® Deja Vibe.

**With QuickMount® mounting plate**

Product No.: RBO B PS T FT4 RBO

**With universal mounting plate**

Product No.: RBO B PS T FT4 UNI

### 12 PedalSafe® Type FT5

Compatible with Fulltone® Full-Drive 3.

**With QuickMount® mounting plate**

Product No.: RBO B PS T FT5 RBO

**With universal mounting plate**

Product No.: RBO B PS T FT5 UNI

## 1 Type G



## 2 Type H



## 3 Type I



## 7 Type J2



## 8 Type K1



## 9 Type K2



## 4 Type J

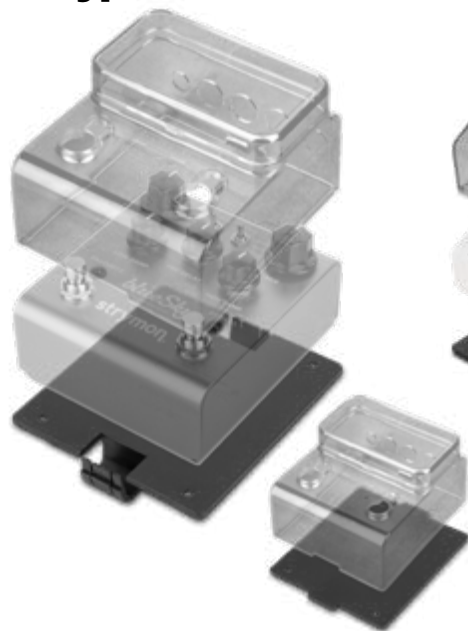

## 5 Type J1.1



## 6 Type J1.2

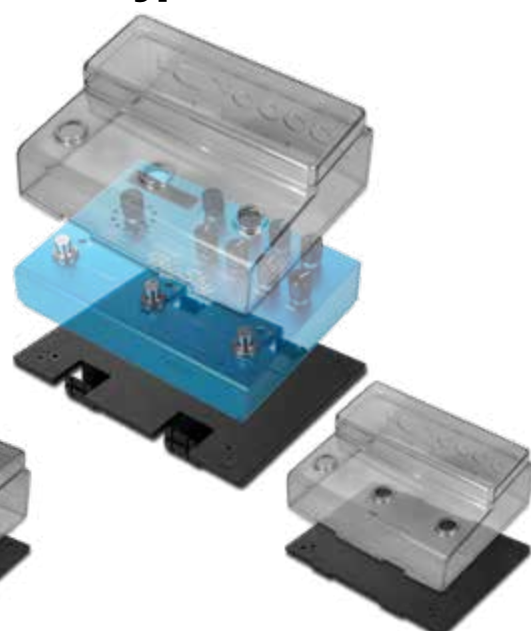

## 10 Type L



## 11 Type L6

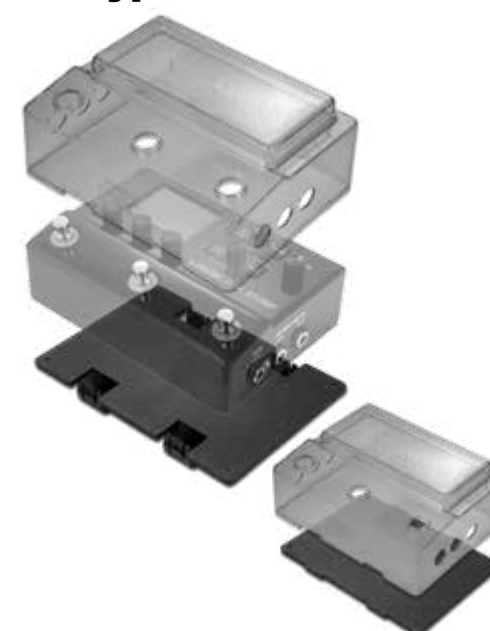

## 12 Type LE1



### 1 PedalSafe® Type G

Compatible with standard size TC Electronic® effects pedals with side mounted jacks.

**With QuickMount® mounting plate**

Product No.: RBO B PS T G RBO

**With universal mounting plate**

Product No.: RBO B PS T G UNI

### 2 PedalSafe® Type H

Compatible with DigiTech® Compact Series effects pedals.

**With QuickMount® mounting plate**

Product No.: RBO B PS T H RBO

**With universal mounting plate**

Product No.: RBO B PS T H UNI

### 3 PedalSafe® Type I

Compatible with Eventide® H9 effects pedals.

**With QuickMount® mounting plate**

Product No.: RBO B PS T I RBO

**With universal mounting plate**

Product No.: RBO B PS T I UNI

### 4 PedalSafe® Type J

Compatible with medium-sized Strymon® effects pedals.

**With QuickMount® mounting plate**

Product No.: RBO B PS T J RBO

**With universal mounting plate**

Product No.: RBO B PS T J UNI

### 5 PedalSafe® Type J1.1

Compatible with Boss® DD-500 / MD-500 / RC-500 / RV-500.

**With QuickMount® mounting plate**

Product No.: RBO B PS T J1.1 RBO

**With universal mounting plate**

Product No.: RBO B PS T J1.1 UNI

### 6 PedalSafe® Type J1.2

Compatible with Strymon® Big Sky / Mobius / Timeline.

**With QuickMount® mounting plate**

Product No.: RBO B PS T J1.2 RBO

**With universal mounting plate**

Product No.: RBO B PS T J1.2 UNI

### 7 PedalSafe® Type J2

Compatible with Strymon® Nightsky / Volante.

**With QuickMount® mounting plate**

Product No.: RBO B PS T J2 RBO

**With universal mounting plate**

Product No.: RBO B PS T J2 UNI

### 8 PedalSafe® Type K1

Compatible with Mooer® micro series effects pedals with a large knob configuration.

**With QuickMount® mounting plate**

Product No.: RBO B PS T K1 RBO

**With universal mounting plate**

Product No.: RBO B PS T K1 UNI

### 9 PedalSafe® Type K2

Compatible with Mooer® micro series effects pedals with multiple small knobs or large display configuration (Micro Preamp Series, New Micro Series, Radar).

**With QuickMount® mounting plate**

Product No.: RBO B PS T K2 RBO

**With universal mounting plate**

Product No.: RBO B PS T K2 UNI

### 10 PedalSafe® Type L

Compatible with MXR® / Pigtronix® / Xotic® / XVive® and many other effects pedals with mini-sized housings.

**With QuickMount® mounting plate**

Product No.: RBO B PS T L RBO

**With universal mounting plate**

Product No.: RBO B PS T L UNI

### 11 PedalSafe® Type L6

Compatible with Line6® HX Stomp.

**With QuickMount® mounting plate**

Product No.: RBO B PS T L6 RBO

**With universal mounting plate**

Product No.: RBO B PS T L6 UNI

### 12 PedalSafe® Type LE1

Compatible with Lehle® Sunday Driver II / P-Split III.

**With QuickMount® mounting plate**

Product No.: RBO B PS T LE1 RBO

**With universal mounting plate**

Product No.: RBO B PS T LE1 UNI

## 1 Type LE2



## 2 Type LE3



## 3 Type LE4



## 7 Type SR1

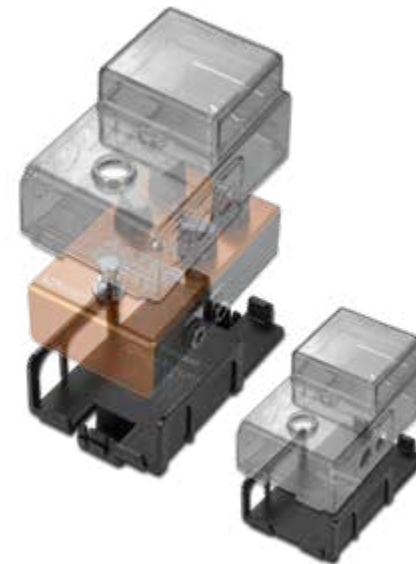

## 8 Type SR2



## 9 Type WH1



## 4 Type MR



## 5 Type N

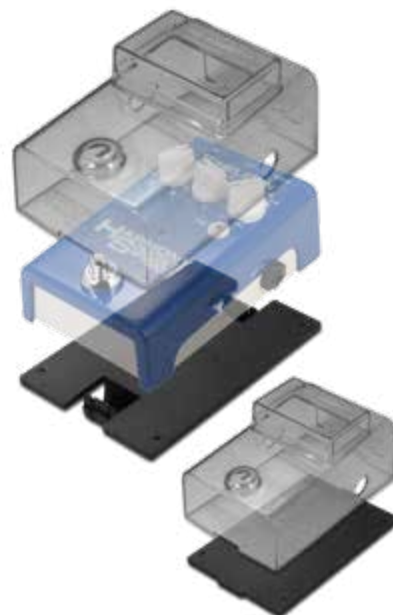

## 6 Type O



## 10 Type WH2

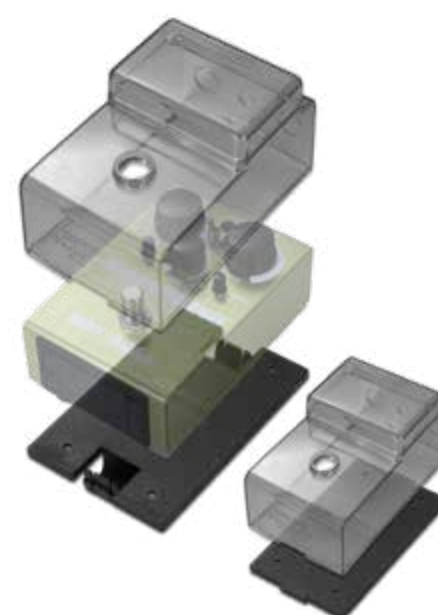

## 11 Type WH3

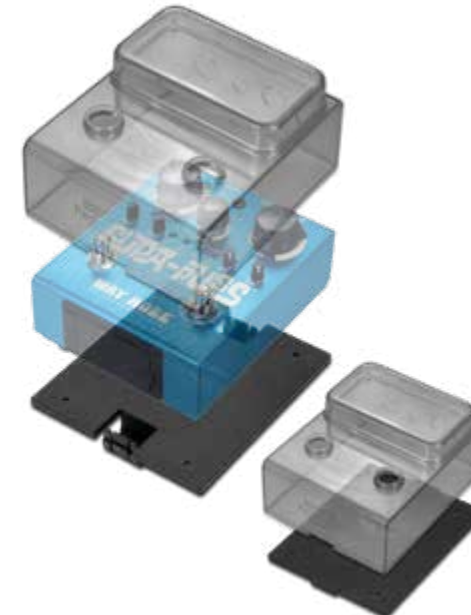

## 12 Pick Box



### 1 PedalSafe® Type LE2

Compatible with Lehle® Little Lehle III / Sunday Driver SW II.

**With QuickMount® mounting plate**

Product No.: RBO B PS T LE2 RBO

**With universal mounting plate**

Product No.: RBO B PS T LE2UNI

### 2 PedalSafe® Type LE3

Compatible with Lehle® Parallel SW II / Little Dual.

**With QuickMount® mounting plate**

Product No.: RBO B PS T LE3 RBO

**With universal mounting plate**

Product No.: RBO B PS T LE3 UNI

### 3 PedalSafe® Type LE4

Compatible with Lehle® Dual / D.Loop / UNI 3@1 / 1@3.

**With QuickMount® mounting plate**

Product No.: RBO B PS T LE4 RBO

**With universal mounting plate**

Product No.: RBO B PS T LE4 UNI

### 4 PedalSafe® Type MR

Compatible with Meris® Pedals (Hedra).

**With QuickMount® mounting plate**

Product No.: RBO B PS T MR RBO

**With universal mounting plate**

Product No.: RBO B PS T MR UNI

### 5 PedalSafe® Type N

Compatible with TC-Helicon® Harmony Singer 2 / Duplicator / Mic Mechanic 2.

**With QuickMount® mounting plate**

Product No.: RBO B PS T N RBO

**With universal mounting plate**

Product No.: RBO B PS T N UNI

### 6 PedalSafe® Type O

Compatible with Friedman® Overdrive Deluxe / Walrus® Descent.

**With QuickMount® mounting plate**

Product No.: RBO B PS T O RBO

**With universal mounting plate**

Product No.: RBO B PS T O UNI

### 7 PedalSafe® Type SR1

Compatible with Source Audio® AfterShock / Vertigo / EQ / True Spring Reverb / Gemini Chorus / C4 Synth.

**With QuickMount® mounting plate**

Product No.: RBO B PS T SR1 RBO

**With universal mounting plate**

Product No.: RBO B PS T SR1 UNI

### 8 PedalSafe® Type SR2

Compatible with Source Audio® VentrisDualReverb / 263 Collider / Nemesis Delay.

**With QuickMount® mounting plate**

Product No.: RBO B PS T SR2 RBO

**With universal mounting plate**

Product No.: RBO B PS T SR2 UNI

### 9 PedalSafe® Type WH1

Compatible with Way Huge® Smalls series.

**With QuickMount® mounting plate**

Product No.: RBO B PS T WH1 RBO

**With universal mounting plate**

Product No.: RBO B PS T WH1 UNI

### 10 PedalSafe® Type WH2

Compatible with Way Huge® Green Rhino / Swollen Pickle.

**With QuickMount® mounting plate**

Product No.: RBO B PS T WH2 RBO

**With universal mounting plate**

Product No.: RBO B PS T WH2 UNI

### 11 PedalSafe® Type WH3

Compatible with Way Huge Supa-Puss.

**With QuickMount® mounting plate**

Product No.: RBO B PS T WH3 RBO

**With universal mounting plate**

Product No.: RBO B PS T WH3 UNI

### 12 Pick Box

A tiny home for your picks and accessories.

**With QuickMount® mounting plate**

Product No.: RBO B QM AC PB

**With universal mounting plate**

Product No.: RBO B PS AC PB

# Bring your board to life

## 1 ISO Power Block V6



## 2 ISO Power Block V6+



### 1 ISO Power Block V6

A multi-power supply for effects pedals with 5 isolated transformers and highly filtered 9V DC power slots and a single 18V DC link output to connect multiple ISO Power Blocks V6 in series for larger setups. The advanced filtering technology used in the 9V DC power slots prevents high-frequency noise. Built with individual slot short circuit protection, connected effects pedals are protected in case of a short circuit. With a designated LED for each power slot indicating the slot is working correctly, you can quickly identify any problems without losing power to the rest of your rig. Incl. 1x 18V DC power adapter (2,000 mA) with interchangeable multi-regional

plug adapters (EU, UK, US/CA, AU/NZ), input voltage 100-240V AC. Incl. 6x RockBoard® Flat Power Cable, 60 cm (for connecting effects pedals). Dimensions (L x W x H): 120 x 70 x 25 mm / 4.72" x 2.76" x 0.98". Weight: 175 g / 6.17 oz. Product No.: RBO POW BLOCK ISO 6

### 2 ISO Power Block V6+

A multi-power supply for effects pedals with 5 isolated transformers and highly filtered power slots (each slot is switchable for 9V / 12V / 15V / 18V) and a single 5V USB output. The RockBoard® ISO Power Block V6+ was designed to power up to 5 effects pedals simultaneously without any noise. The advanced filtering technology used in the

DC power slots prevents high frequency noise. Built with individual slot short circuit protection, connected effects pedals are protected in case of a short circuit. With a designated LED for each power slot indicating the slot is working correctly, you can quickly identify any problems without losing power to the remaining pedals. Incl. 1x 18V DC power adapter (2,000 mA) with interchangeable multi-regional plug adapters (EU, UK, US/CA, AU/NZ), input voltage 100-240V AC. Incl. 5x RockBoard® Flat Power Cable (for connecting effects pedals). Dimensions (L x W x H): 120 x 70 x 26 mm / 4.72" x 2.76" x 1.02". Weight: 195 g / 6.9 oz.

Product No.: RBO POW BLO ISO 6+

## Power Block

The RockBoard® Power Block is a compact, lightweight power supply, delivering current for up to 10 effects pedals. Besides its 8 x 9V (max. 150 mA each) outputs, the Power Block also offers 2 x 18V (400 mA each) power slots. Individual LEDs indicate short circuits for each of the 9V outputs. This power supply provides a maximum total output of 2,000 mA and comes with all necessary connection cables as well as wall socket adapters.

## 3 Power Block V2



### 3 Power Block V2

Includes interchangeable AC adapters, 10 x RockBoard® Flat Power Cables, angled / straight, 50 cm. Dimensions (W x H x D): 105 x 63 x 24 mm / 4.13" x 2.48" x 0.94". Product No.: RBO POW BLOCK

### 4 ISO Power Block V10 V2

Includes interchangeable AC adapters, 10 x RockBoard® Flat Power Cable, 60 cm, 1 x RockBoard® Power Ace Voltage Doubler, Y-Cable, 20 cm, 1 x RockBoard® Power Ace Current Doubler, Y-Cable, 20 cm. Dimensions (W x H x D): 123 x 70 x 26 mm / 4.84" x 2.76" x 1.02". Product No.: RBO POW BLOCK ISO 10

### 5 ISO Power Block V16

16 x RBO cab power 60 AA . Multi Power 100/230V. Includes interchangeable AC adapters. Dimensions (W x H x D): 105 x 63 x 24 mm / 4.13" x 2.48" x 0.94". Product No.: RBO POW BLOCK ISO 16

## 4 ISO Power Block V10 V2



## 5 ISO Power Block V16



# More energy

## 1 ISO Power Block 6 IEC

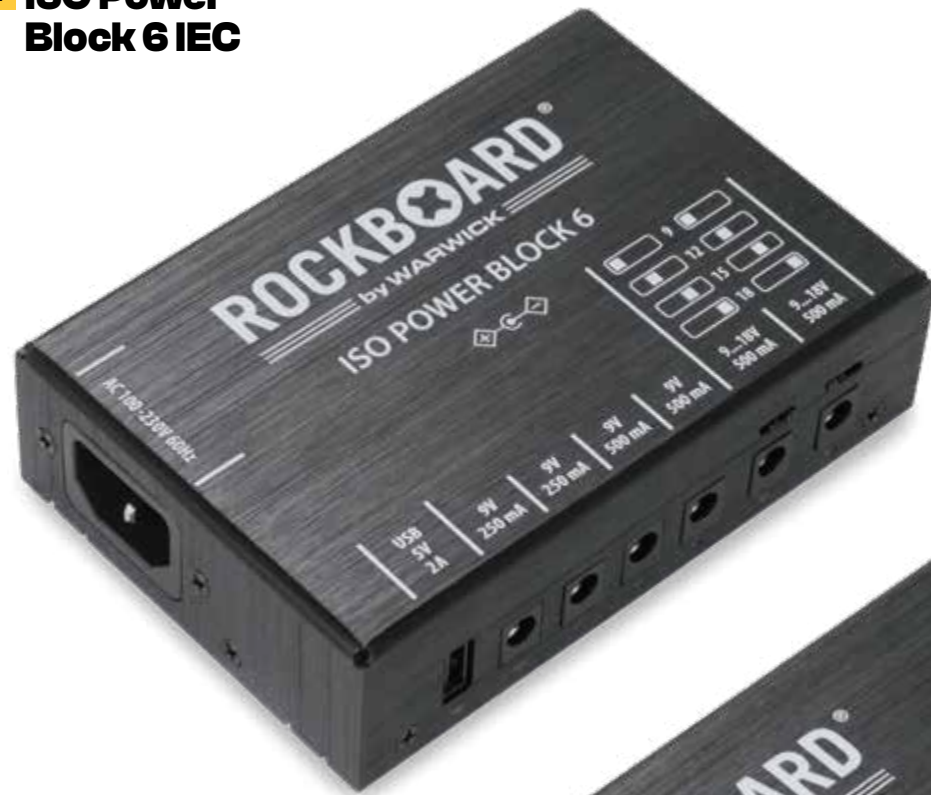

## 2 ISO Power Block 9 IEC



## 3 ISO Power Block 12 IEC

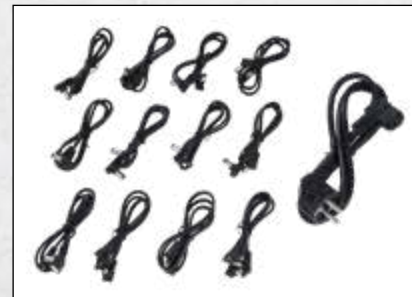
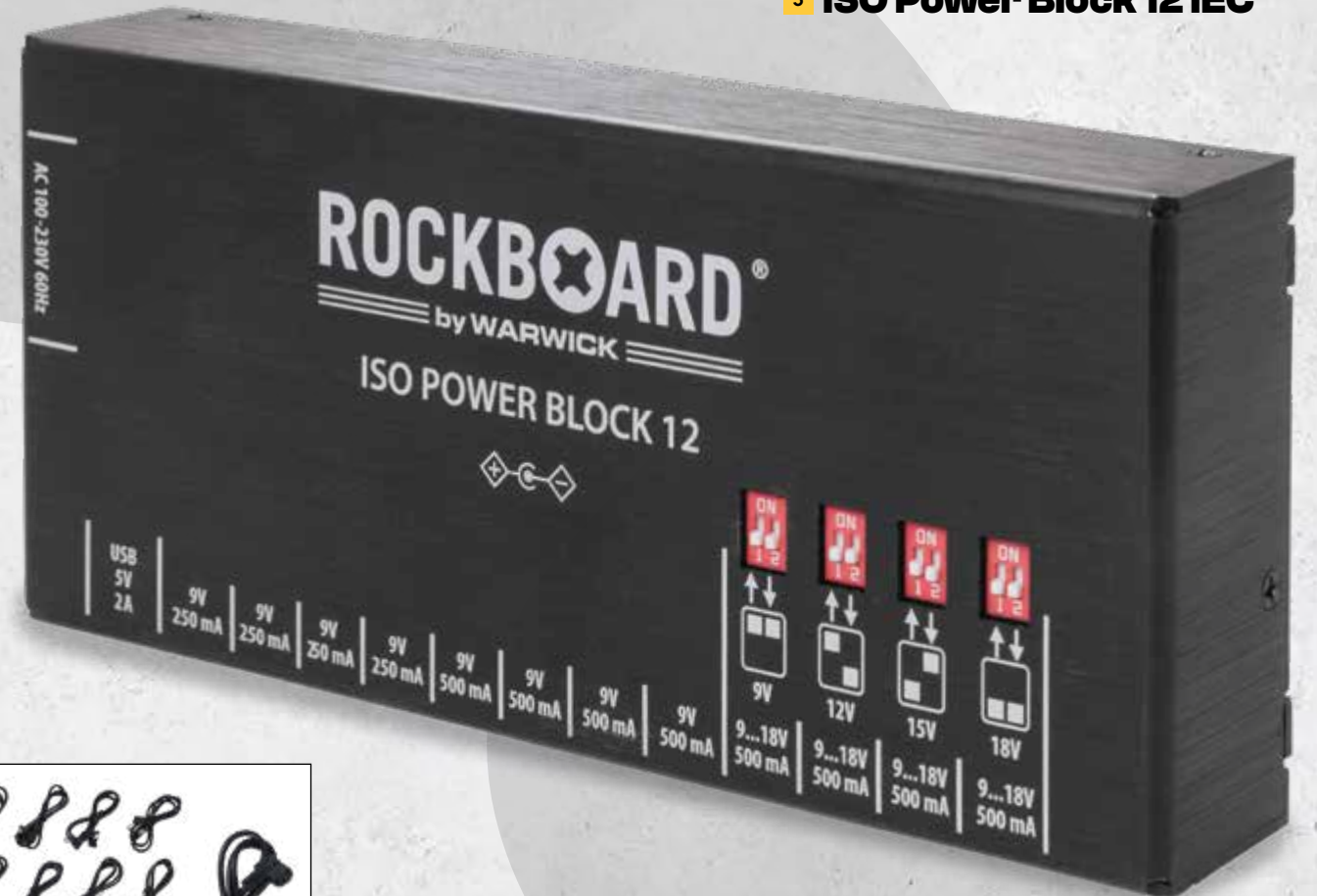

### 1 ISO Power Block 6 IEC

The RockBoard® ISO Power Block 6 IEC was designed to power up to 6 effects pedals simultaneously and without any noise. The advanced filtering technology and electrical isolation used in the DC power slots prevents high frequency noise and hum loops. Your pedals are protected by the short circuit protection built into each individual slot, along with a designated status LED for each power slot that indicates if the slot is working correctly. This means you can quickly identify any problems without losing power to the other pedals. 2 x 9V DC (isolated); max. output 250 mA each. 2 x 9V DC (isolated); max. output 500 mA each. 2 x switchable slots (isolated) with 9V DC / 12V DC / 15V DC / 18V DC; each max. output 500 mA at 9V, 375 mA at 12V, 300 mA at 15V, 250 mA at 18V. 1 x USB 5V; max; max output 2A. Input voltage of 100 to 240 volts and 47 to 63 Hz. Dimensions: (L x W x H): 130 x 88 x 35 mm / 5.12" x 3.46" x 1.38". Weight: 386 g / 13.6 oz. Product No.: RBO POW ISO 6 IEC

### 2 ISO Power Block 9 IEC

The RockBoard® ISO Power Block 9 IEC was designed to power up to 9 effects pedals simultaneously and without any noise. The advanced filtering technology and electrical isolation used in the DC power slots prevents high frequency noise and hum loops. Your effects pedals are protected by the built-in short circuit protection for each individual slot. A designated status LED for each power slot indicates if the slot is working correctly, meaning you can quickly identify any problems without losing power to the other pedals. 3 x 9V DC (isolated); max. output 250 mA each. 3 x 9V DC (isolated); max. output 500 mA each. 3 x switchable slots (isolated) with 9V DC / 12V DC / 15V DC / 18V DC; each max. output 500 mA at 9V, 375 mA at 12V, 300 mA at 15V, 250 mA at 18V. 1 x USB 5V; max; max output 2A. Input voltage of 100 to 240 volts and 47 to 63 Hz. Dimensions: (L x W x H): 195 x 88 x 35 mm / 7.68" x 3.46" x 1.38". Weight: 591 g / 1.3 lbs. Product No.: RBO POW ISO 9 IEC

### 3 ISO Power Block 12 IEC

The RockBoard® ISO Power Block 12 IEC was designed to power up to 12 effects pedals simultaneously and without any noise. The advanced filtering technology and electrical isolation used in the DC power slots prevents high frequency noise and hum loops. Your effects pedals are protected by the built-in short circuit protection for each individual slot. A designated status LED for each power slot indicates if the slot is working correctly, meaning you can quickly identify any problems without losing power to the other pedals. 4 x 9V DC (isolated); max. output 250 mA each. 4 x 9V DC (isolated); max. output 500 mA each. 4 x switchable slots (isolated) with 9V DC / 12V DC / 15V DC / 18V DC; each max. output 500 mA at 9V, 375 mA at 12V, 300 mA at 15V, 250 mA at 18V. 1 x USB 5V; max; max output 2A. Input voltage of 100 to 240 volts and 47 to 63 Hz. Dimensions: (L x W x H): 195 x 88 x 35 mm / 7.68" x 3.46" x 1.38". Weight: 608 g / 1.34 lbs. Product No.: RBO POW ISO 12 IEC



# Check out our new Website – [www.rockboard.de](http://www.rockboard.de)

## Homepage

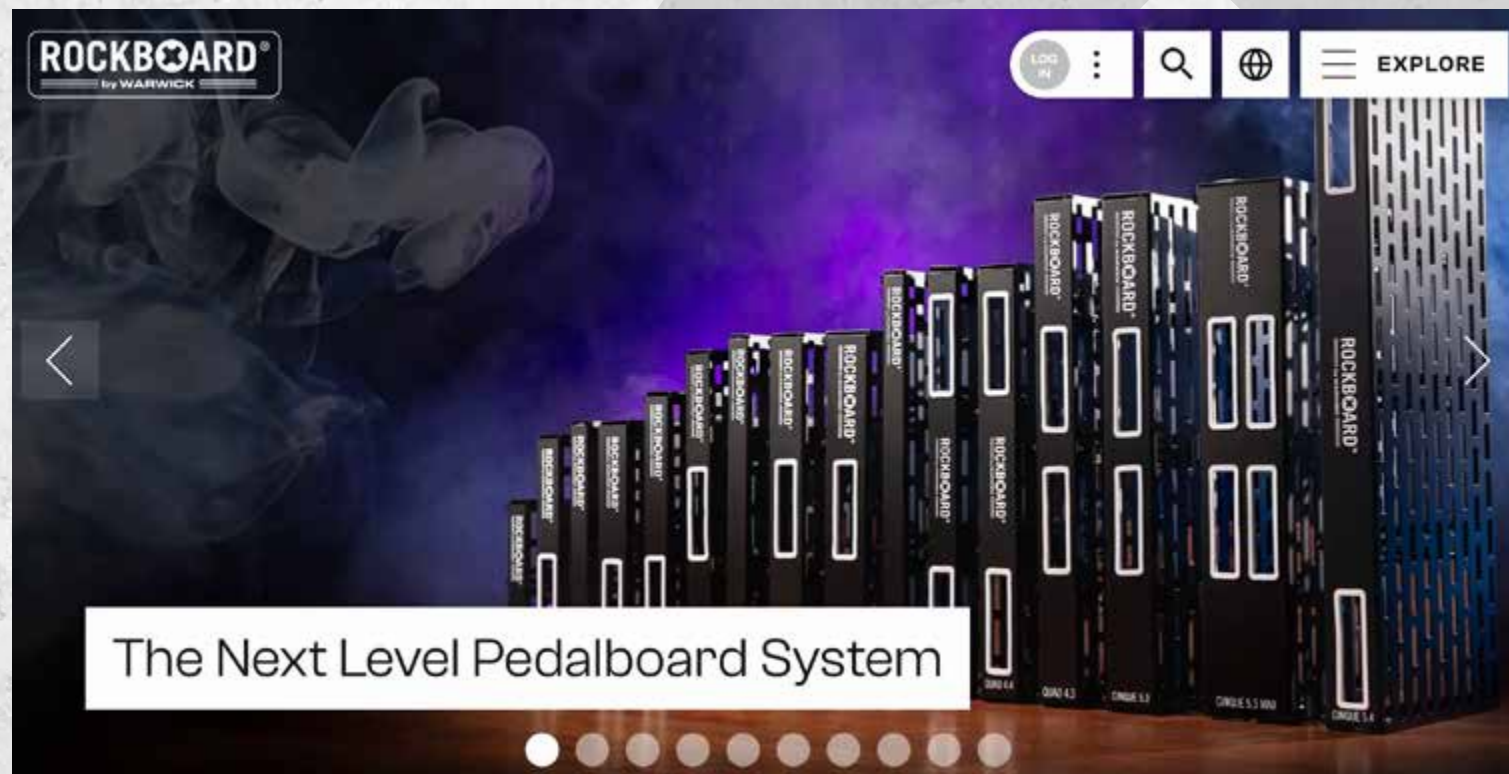

## The smarter Pedalboard

Our pedalboard series has been carefully designed to create a pedalboard that is lightweight, torsionally rigid and robust. The unique and ingenious design is based on a single sheet of cold-rolled aluminum with no welded seams. The result is a completely flat surface that can be used edge-to-edge.

An incredible variety of 16 pedalboards in various sizes, optionally with Gig Bag or Flight Case, leaves nothing to be desired. You can quickly find the right pedalboard for almost any application ... if you can't find the perfect solution here, you probably don't need a pedalboard at all.



## About

**New - Fast - Fresh - Comprehensive - Informative - Creative - Communicative ...**

... that's how the new RockBoard® website presents itself. Here you can find really everything that is related to effects and pedalboards. Certainly, some of the features have never been seen before!

- of course you will find all the information and facts about pedalboards, patchbays, QuickMount® mounts, PedalSafe® protective covers, power supplies, cables and all the available accessories from the huge RockBoard® range

- a highlight is the board configurator, with which you can easily plan your new pedalboard virtually thanks to our huge database of pedals and 16 different board sizes. Even wiring and signal flow can be simulated. Your board can then be shared and discussed with other users

- in the PedalPedia database you will find thousands of pedals with pictures and technical data

- in the Pedalboard Gallery you can present your board and view and discuss ideas with other users

## Board Configurator



[Click here to reach the Board configurator](#)

## Pedal Creator

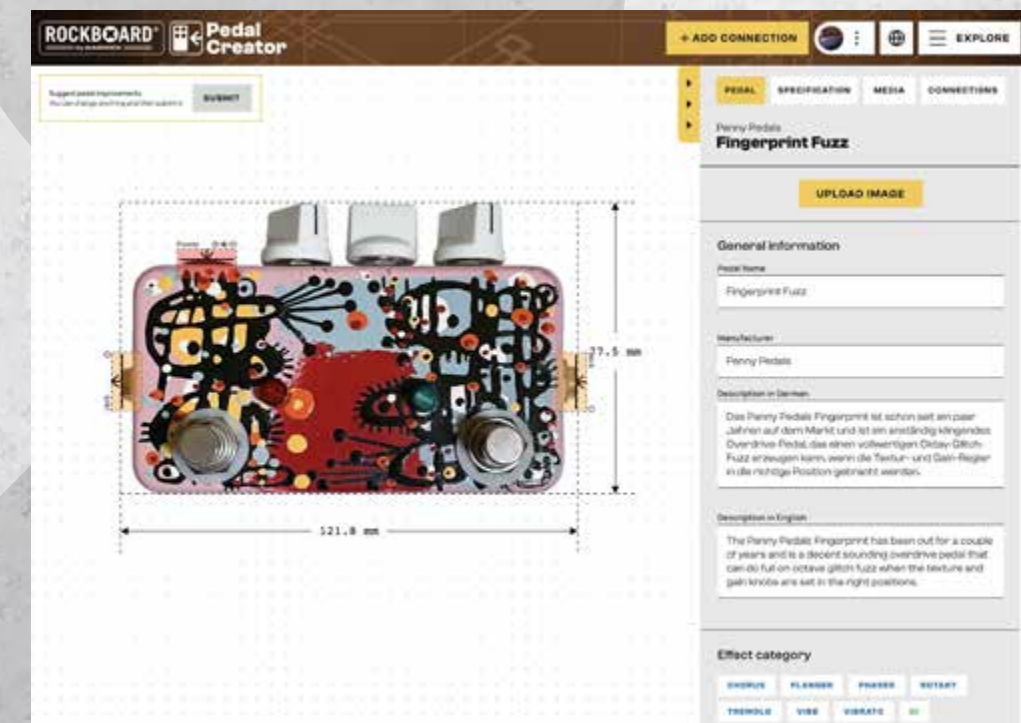

# Power supplies

## RockBoard® Power Adapters

Equipped with multi-regional plug adapters and automatic voltage switching, our power adapters can be used almost everywhere around the globe.



**1 Power Supply**

# Flexibility for your effects

**1 Power Supply 9V DC/500 & 9V DC/1000**  
The new highly filtered RockBoard® power supply is characterized by a high-quality design and hum-free operation and delivers stable and clean 9V DC with a current consumption of either 500 mA or 1000 mA.  
**Power Supply 9V DC/500**  
Product No.: RBO POWER 9V DC/500  
**Power Supply 9V DC/1000**  
Product No.: RBO POWER 9V DC/1000

**2 Power ACE**  
9V DC 1700 mA, Power Supply, with interchangeable AC adapters.  
Product No.: RBO POWER ACE

**3 Power ACE 25**  
9V DC 2500 mA, Power Supply, with interchangeable AC adapter.  
Product No.: RBO POWER ACE 25

**4 Power ACE Set**  
9V DC 1700 mA, Power Supply + Cabling, with interchangeable AC adapters. Incl. 1x RockBoard® Power Ace Battery Clip Converter. Incl. 1x RockBoard® Power Ace Mini Jack Converter. Incl. 1x RockBoard® Power Ace Polarity Converter. Incl. 1x RockBoard® Power Ace Barrel Plug Converter.  
Product No.: RBO POWER ACE SET

**5 ISO Power Adapter PS 18**  
18V DC 2A Power Supply, with interchangeable AC adapters. For ISO POWER BLOCK V6, V6+, V10, V16.  
Product No.: RBO POW BLO PS 18

**4 Power ACE Set**



**5 ISO Power Adapter PS 18**



**2 Power ACE**



**3 Power ACE 25**

# Adapter cables

## 1 Intelligent Voltage Converter

SOON



### 1 Intelligent Voltage Converter

The Intelligent Voltage Converter reliably transforms an input voltage of 9 to 15 V DC from your power supply into a stable output voltage of 18V DC with an impressive 200 mA. The advanced technology ensures highly accurate and low-noise voltage regulation and will optimize the operation of your high-end effects pedals.

Product No.: RBO POWER IVC 200

### 2 Power ACE USB & PD

The RBO POWER ACE USB & PD cables convert USB input power to stable 9V, 12V or 18V.

Product No.: RBO POWER ACE USB 9V

Product No.: RBO POWER ACE USB18V

Product No.: RBO POWER ACE PD 12V

Product No.: RBO POWER ACE PD 9V

### 3 Power ACE IEC Connector Cable

IEC male to female connector cable. Connects RockBoard® MOD patchbays with multi-power supplies. Length 35 cm / 13.78".

Product No.: RBO POWER ACE IEC

### 4 Power ACE Voltage Doubler Y Cable

For combining voltage output of two isolated power slots. 2 x straight 2.1x5.5 mm barrel plugs (black) wired in parallel to 1 x 2.1 x 5.5 mm barrel socket (blue).

Product No.: RBO POWER ACE Y VD

### 5 Power ACE Current Doubler Y Cable

For combining current output of two isolated power slots. 2 x straight 2.1 x 5.5 mm barrel plugs (black) wired in parallel to 1 x 2.1 x 5.5 mm barrel socket (white).

Product No.: RBO POWER ACE Y CD

### 6 Power ACE Mini Jack Converter

2.1 mm x 5.5 mm barrel connector female to 3.5 mm / 1/8" mini plug. For effects pedals with 3.5 mm power supply jack.

Product No.: RBO POWER ACE CON3,5

### 7 Power ACE Polarity Converter

2.1 x 5.5 mm female barrel connector (-) center to 2.1 x 5.5 mm barrel plug (+) center. Inverts polarity from (-) center to (+) center. For effects pedals with polarity (+) center power supply sockets.

Product No.: RBO POWER ACE CONREV

### 8 Power ACE Barrel Plug Converter

2.1 x 5.5 mm female barrel connector to 2.5 x 5.5 mm barrel plug. For effects pedals with 2.5 x 5.5 mm power socket.

Product No.: RBO POWER ACE CONL6

### 9 Power ACE Battery Clip Converter

2.1 x 5.5 mm female barrel connector to 9V battery clip. For effects pedals without power supply jack.

Product No.: RBO POWER ACE CONBAT

## 2 Power ACE USB & PD

SOON



Images similar

## 3 Power ACE IEC Connector Cable



## 4 Power ACE Voltage Doubler Y Cable



## 5 Power ACE Current Doubler Y Cable



## 6 Power ACE Mini Jack Converter



## 7 Power ACE Polarity Converter



## 8 Power ACE Barrel Plug Converter



## 9 Power ACE Battery Clip Converter



## RockBoard® Flat Power and Flat Daisy Chain Cables

The RockBoard® Flat Power Cables and Flat Daisy Chain Cables are high-quality power supply cables for effects pedals that were developed based on our Flat Patch Cables. Their super compact plugs are smaller than most other power cables on the market.

Unlike most commonly available power cables, RockBoard® Flat Power and Daisy Chain Cables do not use two parallel cable lines. Instead, they use the same solid design as instrument cables with a central wire surrounded by a shielding layer. This prevents electrical interference in the audio signal.

# Lose the bulk, keep the power

**1 Flat Power Cable Angled / Angled**



**2 Flat Power Cable Angled / Straight**



**3 Flat Daisy Chain Cable**



**3 Flat Daisy Chain Cable**

Designed like instrument cables with twisted copper shielding to minimize electrical interference. 5.5 x 2.1 mm barrel plugs. Length between plugs: 30 cm / 11.81". Plug dimensions (L x W x H): 20 x 9 x 10.5 mm / 0.78" x 0.35" x 0.39" (angled) 20.5 x 11 x 8.5 mm / 0.79" x 0.43" x 0.31" (straight).

**1 Flat Power Cables Angled / Angled**

Size	Product No.
15 cm / 5.91"	RBO CAB POWER 15 AA
30 cm / 11.81"	RBO CAB POWER 30 AA
60 cm / 23.62"	RBO CAB POWER 60 AA

**2 Flat Power Cables Angled / Straight**

Size	Product No.
15 cm / 5.91"	RBO CAB POWER 15 AS
30 cm / 11.81"	RBO CAB POWER 30 AS
60 cm / 23.62"	RBO CAB POWER 60 AS



**Flat Polarity Reverser Cable**

Plugs	Size	Product No.
Angled / Angled	2 Outputs	RBO CAB POWER DC2 A
Angled / Straight	2 Outputs	RBO CAB POWER DC2 S
Angled / Angled	4 Outputs	RBO CAB POWER DC4 A
Angled / Straight	4 Outputs	RBO CAB POWER DC4 S
Angled / Angled	6 Outputs	RBO CAB POWER DC6 A
Angled / Straight	6 Outputs	RBO CAB POWER DC6 S
Angled / Angled	8 Outputs	RBO CAB POWER DC8 A
Angled / Straight	8 Outputs	RBO CAB POWER DC8 S
Angled / Straight	Flat Polarity Reverser Cable, Red	RBO CAB POWER REV AS

# Instrument cables

## Flat Instrument Cables

The RockBoard® Flat Instrument Cable is extra flat and super-flexible. It features a slim rectangular body and extra thin plugs to prevent cable tangle as well as lead breakage. This guarantees a clean signal path and pristine signal quality. Both the RockBoard® Flat Instrument Cable and RockBoard® Premium Flat Instrument Cable are available in three different configurations and two lengths.

### 1 Flat Instrument Cable



### 2 Premium Flat Instrument Cable



#### 1 Flat Instrument Cable

Flat instrument lead cable. Super flat connectors. Operating Temperature: -15°C to +70°C / 5°F to 158°F. Flexible copper conductor: 20x0.12 mm / 36 AWG. Signal Insulation: PE (polyethylene). Flexible twisted copper shielding: 34 x 0.12 mm / 36 AWG. Outer Insulation: PVC. Capacitance Cond. / Shield: < 10 pF / decimeters. Conductor Resistance: < 10 mOhm / decimeters. 6.3 mm / 1/4" mono audio plugs. Outer dimensions cable: 7x3 mm / 0.28" x 0.12" (rectangular). Outer dimensions plugs: Straight (WxH): 12.5x12.5 mm / 0.49" x 0.49". Angled (W x H): 12.5 x 7.5 mm / 0.49" x 0.49".

#### 2 Premium Flat Instrument Cable

High-end flat instrument lead cable with rectangular profile. Flexible copper conductor 50 x 0.12 mm (36 AWG). Signal Insulation PE (polyethylene 0.29 mm / 0.11"). Semi-conductive layer (0.5 mm / 0.02") between signal. Insulated and shielded to prevent cable microphonics. 100% braided tinned copper shielding 16 x 4 x 0.15 mm (34 AWG). Aluminum foil shield (0.06 mm / 0.002"). Capacitance cond./shield less than 8 pF / decimeter. Conductor Resistance less than 8 mOhm / decimeter. Operating Temperature - 15° C to + 70° C / 5° F to 158° F. Gold-plated 6.3 mm / 1/4" mono audio plugs. Outer dimension of Cable: 7.6 x 4.8 mm / 0.30" x 0.19" (rectangular). Outer dimensions plugs (L x W x H): 43.5 x 16 x 11.5 mm / 1.71" x 0.63" x 0.45".

Size	Plugs	Product No.
3 m / 9.8 ft	Angled / Angled	RBO CAB FL 300BLK AA
3 m / 9.8 ft	Straight / Angled	RBO CAB FL 300BLK SA
3 m / 9.8 ft	Straight / Straight	RBO CAB FL 300BLK SS
6 m / 19.7 ft	Angled / Angled	RBO CAB FL 600BLK AA
6 m / 19.7 ft	Straight / Angled	RBO CAB FL 600BLK SA
6 m / 19.7 ft	Straight / Straight	RBO CAB FL 600BLK SS

Size	Plugs	Product No.
3 m / 9.8 ft	Angled / Angled	RBO CAB FL PR 300 AA
3 m / 9.8 ft	Straight / Angled	RBO CAB FL PR 300 SA
3 m / 9.8 ft	Straight / Straight	RBO CAB FL PR 300 SS
6 m / 19.7 ft	Angled / Angled	RBO CAB FL PR 600 AA
6 m / 19.7 ft	Straight / Angled	RBO CAB FL PR 600 SA
6 m / 19.7 ft	Straight / Straight	RBO CAB FL PR 600 SS

# Save space, connect more



**1 Flat Patch Cable Black Series**

**2 Flat Patch Cable Gold Series**



**3 Flat Patch Cable Sapphire Series**



## Flat Patch Cables

RockBoard® Patch Cables are extra flat and space-saving. Designed to optimize pedalboard real estate, they feature a slim rectangular body and extra thin, angled plugs, to help keep your setup organized.

**1 Flat Patch Cable Black Series**

Size	Product No.
5 cm / 1.97"	RBO CAB PC F 5 BLK
5 cm / 1.97"	RBO CAB PC F 5 BW (Bowl with 50 pcs.)
10 cm / 3.94"	RBO CAB PC F 10 BLK
20 cm / 7.87"	RBO CAB PC F 20 BLK
30 cm / 11.81"	RBO CAB PC F 30 BLK
45 cm / 17.72"	RBO CAB PC F 45 BLK
60 cm / 23.62"	RBO CAB PC F 60 BLK
80 cm / 31.50"	RBO CAB PC F 80 BLK
100 cm / 39.37"	RBO CAB PC F 100 BLK
120 cm / 47.24"	RBO CAB PC F 120 BLK
140 cm / 55.12"	RBO CAB PC F 140 BLK

**2 Flat Patch Cable Gold Series**

Size	Product No.
5 cm / 1.97"	RBO CAB PC F 5 GD
10 cm / 3.94"	RBO CAB PC F 10 GD
20 cm / 7.87"	RBO CAB PC F 20 GD
30 cm / 11.81"	RBO CAB PC F 30 GD
45 cm / 17.72"	RBO CAB PC F 45 GD
60 cm / 23.62"	RBO CAB PC F 60 GD
80 cm / 31.50"	RBO CAB PC F 80 GD
100 cm / 39.37"	RBO CAB PC F 100 GD
120 cm / 47.24"	RBO CAB PC F 120 GD
140 cm / 55.12"	RBO CAB PC F 140 GD

**3 Flat Patch Cable Sapphire Series**

Size	Product No.
5 cm / 1.97"	RBO CAB PC F 5 SP
10 cm / 3.94"	RBO CAB PC F 10 SP
20 cm / 7.87"	RBO CAB PC F 20 SP
30 cm / 11.81"	RBO CAB PC F 30 SP
45 cm / 17.72"	RBO CAB PC F 45 SP
60 cm / 23.62"	RBO CAB PC F 60 SP
80 cm / 31.50"	RBO CAB PC F 80 SP
100 cm / 39.37"	RBO CAB PC F 100 SP
120 cm / 47.24"	RBO CAB PC F 120 SP
140 cm / 55.12"	RBO CAB PC F 140 SP

**4 Bender75**



**4 Bender75**

Size	Product No.
7.5 cm / 2.95"	RBO CAB PC F B75 BLK
7.5 cm / 2.95"	RBO CAB PC F B75 BW (Bowl with 50 pcs.)

**5 Flat Patch Cable Salt & Pepper Tweed Series**

Size	Product No.
5 cm / 1.97"	RBO CAB PC F 5 SPT
10 cm / 3.94"	RBO CAB PC F 10 SPT
20 cm / 7.87"	RBO CAB PC F 20 SPT
30 cm / 11.81"	RBO CAB PC F 30 SPT
60 cm / 23.62"	RBO CAB PC F 60 SPT

**6 Flat Patch Cable Vintage Tweed Series**

Size	Product No.
5 cm / 1.97"	RBO CAB PC F 5 VT
10 cm / 3.94"	RBO CAB PC F 10 VT
20 cm / 7.87"	RBO CAB PC F 20 VT
30 cm / 11.81"	RBO CAB PC F 30 VT
60 cm / 23.62"	RBO CAB PC F 60 VT

**7 Black Coiled Cable Series**

Size	Product No.
30 cm / 11.81"	RBO CAB PC F 30 CC
50 cm / 19.69"	RBO CAB PC F 50 CC
100 cm / 39.37"	RBO CAB PC F 100 CC
150 cm / 59.06"	RBO CAB PC F 150 CC

**5 Flat Patch Cable Salt & Pepper Tweed Series**



**6 Flat Patch Cable Vintage Tweed Series**



**7 Black Coiled Cable Series**

## Specifications for RockBoard® Flat Patch Cables:

- Flat patch cables with rectangular profile
- Compact and super flat angled plugs
- Flexible copper conductor 20 x 0.12 mm / 36 AWG
- Twisted copper shielding 34 x 0.12 mm / 36 AWG
- Capacitance of less than 10 pF/decimeters
- Conductor resistance of less than 10 mOhm/decimeters
- Angled 6.3 mm / 1/4" mono audio plugs
- Operating temperature: -15° C to +70° C / 5° F to 158° F
- Outer dimensions cable (W x H): 7 x 3 mm / 0.28" x 0.12" (rectangular)
- Outer dimensions plugs (W x H): 12.5 x 7.5 mm / 0.49" x 0.30"



# Customized and solderless

## RockBoard® PatchWorks® – Solderless Patch Cables

The RockBoard® PatchWorks® Solderless Patch Cables are the first of their kind because they can be assembled with exactly the plug you need! The ingenious and easy-to-use design has a two-piece plug that can be changed from straight to angled simply by turning one part by 90 degrees. Using professional-grade, high-quality cable and connectors with gold-plated tips, the RockBoard® PatchWorks® give you everything you could desire for your hi-fi pedalboard. Build your own patch cables, in exactly the lengths that you need them while also cutting down on excess cable path and curbing signal loss.

### 1 Solderless Set



**1 PatchWorks® Solderless Set**  
10 Plugs. Cable  $\varnothing$  4 mm / 0.16", 3 m / 9.8 ft. 80 pF / m, 37 mOhm/m. 1x Cable Cutter. 1x Hex Key.

**Chrome**  
Product No.: RBO CAB PW SET CR

**Gold**  
Product No.: RBO CAB PW SET GD

### 2 PatchWorks® Solderless Plugs

Set of 2 pcs. 1 Hex Key.

**Chrome**  
Product No.: RBO CAB PW PLUG 2 CR

**Gold**  
Product No.: RBO CAB PW PLUG 2 GD

### 3 PatchWorks® Solderless Plugs

Set of 6 pcs. 1 Hex Key.

**Chrome**  
Product No.: RBO CAB PW PLUG 6 CR

**Gold**  
Product No.: RBO CAB PW PLUG 6 GD

### 4 PatchWorks® Solderless Cable

Cable  $\varnothing$  4 mm / 0.16". 80 pF/m, 37 mOhm/m.

**3 m / 9.8 ft**  
Product No.: RBO CAB PW CAB 3

**6 m / 19.7 ft**  
Product No.: RBO CAB PW CAB 6

### 5 PatchWorks® Cable Cutter

For PatchWorks® solderless patch cable system. Easy to use. Makes precise and smooth cuts. 4 mm inlet specifically designed for PatchWorks® Solderless Cable.

Product No.: RBO CAB PW CUTTER

### 6 PatchWorks® TX8 Wrench

Spare TX8 wrench for PatchWorks® solderless cable system. TX8 hexalobular internal wrench. Product No.: RBO CAB PW HEXKEY

### 7 PatchWorks® Spare TX Screws

Spare TX8 screws for PatchWorks® solderless plugs. M2 x 4 mm threads. 4 mm countersunk screw heads. Set of 10 pcs.

Product No.: RBO CAB PW SCREW

### 2 Solderless Plugs 2 pcs.



Chrome

### 3 Solderless Plugs 6 pcs.



Gold

### 4 Solderless Cable



### 5 Cable Cutter



### 6 TX8 Wrench



### 7 Spare TX Screws



# Stay connected

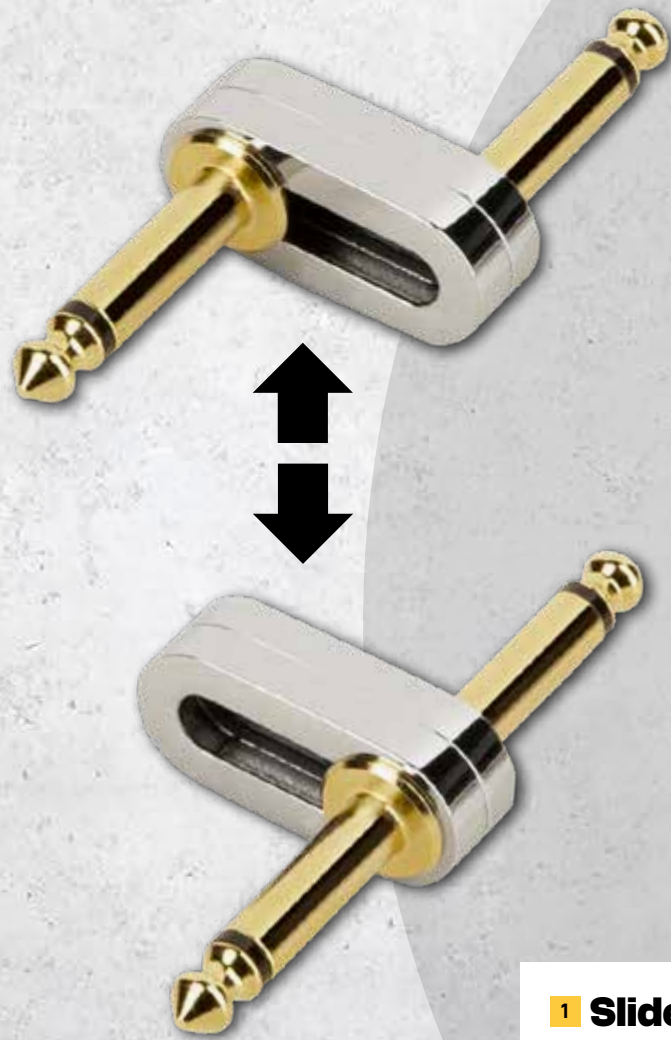

## Slider Plug

The RockBoard® Slider Plug is a super-compact pedal connector (jack coupler) with adjustable plug position. The width of approx. 12 millimeters (1/2"), makes your pedals come closer together. Using the 6.3 mm (1/4") Slider Plug guarantees a short, clean signal path and pristine signal quality.

## 1 Slider Plug

### 1 Slider Plug

Pedal connector with adjustable plug offset. Shortest possible distance between pedals. Gold-plated connectors. 6.3 mm / 1/4" mono audio plugs on both sides. Length (plug to plug): 12 mm / 0.47". Offset (plug to plug): adjustable from 0 - 20 mm / 0" - 0.79".

Color	Product No.
Chrome	RBO PC SLIDE CHR
Gold	RBO PC SLIDE GD



Chrome

Gold

## Connectors

### 2 Straight Connector



### 3 Z-Shaped Connector

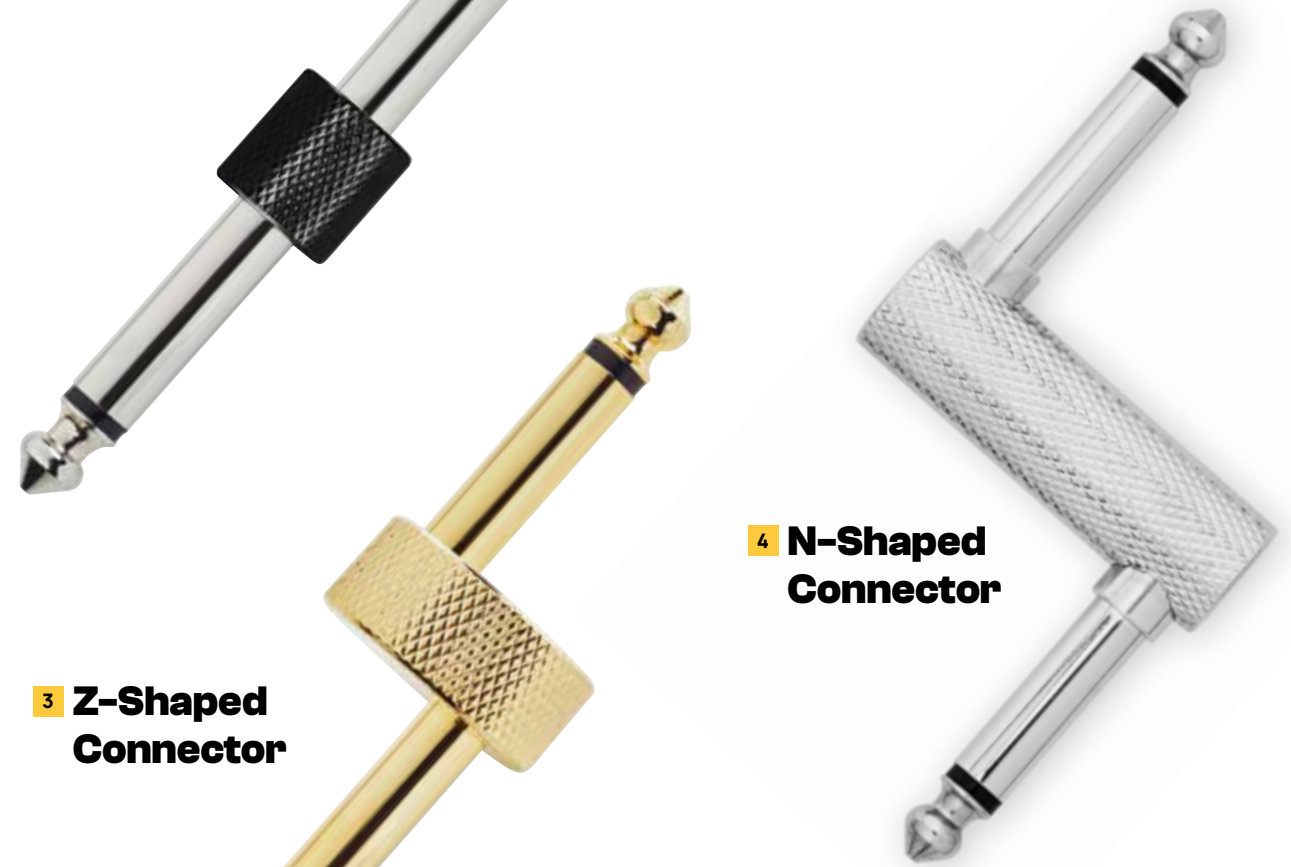

### 4 N-Shaped Connector

### 2 Straight Connectors

Straight pedal connector. Connects side-mounted jacks. Suitable for pedals with standard, rectangular housing. 6.3 mm / 1/4" mono audio plugs on both sides. Length (plug to plug): 12 mm / 0.47".

Color	Product No.
Black	RBO PC S BK
Gold	RBO PC S GD
Nickel	RBO PC S NK

### 3 Z-Shaped Connectors

Offset pedal connector. Connects offset side-mounted jacks. Suitable for pedals with standard, rectangular housing. 6.3 mm / 1/4" mono audio plugs on both sides. Length (plug to plug): 10 mm / 0.39".

Color	Product No.
Black	RBO PC Z BK
Gold	RBO PC Z GD
Nickel	RBO PC Z NK

### 4 N-Shaped Connectors

Offset pedal connector. Connects offset side-mounted jacks. Suitable for pedals with standard, rectangular housing. 6.3 mm / 1/4" mono audio plugs on both sides. Length (plug to plug): 19 mm / 0.75".

Color	Product No.
Black	RBO PC N BK
Gold	RBO PC N GD
Nickel	RBO PC N NK



## 1 Flat XLR Cable



### Flat XLR Cables

The RockBoard® PREMIUM Flat XLR Cables are professional grade cables made with the utmost care. Designed and developed in Germany, these cables feature select, high-grade materials that prevent twisting and help protect against accidental damage. Enhanced shielding against high and low frequency interference and a flexible conductor core make this cable the rival of all other leading brands on the market. Prevent unwanted noise in your signal and preserve your unaltered, natural tone with the RockBoard® Premium Flat XLR Cable.



## 2 Flat Patch TRS Cable



Y Splitter Cable

### 1 Flat XLR Cable

2x flexible copper conductor 20 x 0.12 mm (36 AWG). Braided copper shielding 16 x 4 x 0.12 mm (36 AWG). Capacitance of less than 10 pF/decimeters. Conductor resistance of less than 10 mOhm/decimeter. Operating temperature: -15°C to +70°C. Outer cable dimensions: 7 x 3 mm / 0.28" x 0.12".

Size	Product No.
30 cm / 11.81"	RBO CAB F XLR 30 BK
60 cm / 23.62"	RBO CAB F XLR 60 BK
90 cm / 35.43"	RBO CAB F XLR 90 BK
3 m / 9.8 ft	RBO CAB F XLR 300 BK
6 m / 19.7 ft	RBO CAB F XLR 600 BK
9 m / 29.5 ft	RBO CAB F XLR 900 BK

### 2 Flat Patch TRS Cable

Flat TRS cable with rectangular angled profile. For connecting foot controllers and expression pedals. Compact and super flat angled plugs. Flexible copper conductor 20 x 0.12 mm. Twisted copper shielding 34 x 0.12 mm. PE (polyethylene) signal insulation. Outer PVC insulation. Capacitance of less than 10 pF/decimeters. Conductor resistance of less than 10 mOhm/decimeters. Angled 6.3 mm / ¼" TRS audio plugs. Operating temperature: -15°C to +70°C. Outer dimensions cable (W x H): 7 x 3 mm / 0.28" x 0.12" (rectangular). Outer dimensions plugs (W x H): 12.5 x 7.5 mm / 0.49" x 0.30".

Size	Product No.
15 cm / 5.91"	RBO CAB F TRS 15 BK
30 cm / 11.81"	RBO CAB F TRS 30 BK
60 cm / 23.62"	RBO CAB F TRS 60 BK
120 cm / 47.24"	RBO CAB F TRS 120 BK
3 m / 9.8 ft	RBO CAB F TRS 300 BK
6 m / 19.7 ft	RBO CAB F TRS 600 BK
20 cm / 7.87" Y Splitter Cable	RBO CAB F Y 20 BK
30 cm / 11.81" Y Splitter Cable	RBO CAB F Y 30 BK
50 cm / 19.69" Y Splitter Cable	RBO CAB F Y 50 BK

## 3 Flat Looper/Switcher Connector Cable



## 4 Flat Looper/Switcher Connector Cable Gold Series



### 3 Flat Looper/Switcher Connector Cable

Flat patch cables with rectangular profile. Compact and super flat angled/straight plugs. Perfect for use with looper/switchers or effects pedals with tightly spaced jacks. Flexible copper conductor (20 x 0.12 mm / 36 AWG). Twisted copper shielding (34 x 0.12 mm / 36 AWG). PE (polyethylene) signal insulation. PVC cable mantle. Capacitance less than 10 pF/decimeters. Conductor resistance less than 10 mOhm/decimeters. 6.3 mm mono audio plugs. Operating temperature -15°C to +70°C / 5°F to 158°F / 5°F to 158°F. Outer dimensions cable (W x H) 7 x 3 mm / 0.28" x 0.12" (rectangular). Outer dimensions plugs (W x H) 12.5 x 7.5 mm / 0.49" x 0.30" (angled), 12.5 x 12.5 mm / 0.49" x 0.49" (straight).

Size	Plugs	Product No.
20 cm / 7.87"	Straight / Angled	RBO CAB PC F 20 BSA
40 cm / 15.75"	Straight / Angled	RBO CAB PC F 40 BSA
60 cm / 23.62"	Straight / Angled	RBO CAB PC F 60 BSA
100 cm / 39.37"	Straight / Angled	RBO CAB PC F 100 BSA

### 4 Flat Looper/Switcher Connector Cable Gold Series

High quality, double shielded flat patch cables with a rectangular profile. Compact and super flat plugs. Gold-plated connectors. Metal plug housings. Flexible copper conductor (20 x 0.12 mm / 36 AWG). 90% braided tinned copper shielding (4 x 16 x 0.12 mm / 36 AWG). Additional aluminum foil shielding. PE (polyethylene) signal insulation. PVC cable mantle. Capacitance less than 10 pF/decimeter. Conductor resistance less than 10 mOhm/decimeter. Angled 6.3 mm mono audio plugs. Operating temperature -15°C to +70°C / 5°F to 158°F. Outer dimensions cable (W x H) 7 x 3 mm / 0.28" x 0.12" (rectangular). Outer dimensions plugs (W x H) 12.5 x 7.5 mm / 0.49" x 0.30" (angled), 12.5 x 12.5 mm / 0.49" x 0.49" (straight). Black with gold-plated plug housings.

Size	Plugs	Product No.
20 cm / 7.87"	Straight / Angled	RBO CAB PC F 20 GSA
40 cm / 15.75"	Straight / Angled	RBO CAB PC F 40 GSA
60 cm / 23.62"	Straight / Angled	RBO CAB PC F 60 GSA
100 cm / 39.37"	Straight / Angled	RBO CAB PC F 100 GSA

## 1 Flat Patch MIDI Cable



### 1 Flat Patch MIDI Cable

Compact and super flat angled plugs and cable. Flexible oxygen free copper conductors 5 x 7 x 0.12 mm. Suitable for Clock/SYNC Capabilities & Phantom Power. Max. rated current 1A. Angled DIN 5 pin connectors. Operating temperature -20° C to +60° C. Outer dimensions cable (W x H): 6.5 x 3.5 mm / 0.26" x 0.14" (rectangular). Plug dimensions (L x W x H): 33 x 15 x 10 mm / 1.30" x 0.59" x 0.39". Black.

Size	Product No.
30 cm / 11.81"	RBO CAB MIDI 30 BK
60 cm / 23.62"	RBO CAB MIDI 60 BK
100 cm / 39.37"	RBO CAB MIDI 100 BK
2 m / 6.5 ft	RBO CAB MIDI 200 BK
3 m / 9.8 ft	RBO CAB MIDI 300 BK
5 m / 16.4 ft	RBO CAB MIDI 500 BK
10 m / 32.8 ft	RBO CAB MIDI 1000 BK

### 2 Flat TRS to MIDI Cable

Flat TRS to MIDI cable with a rectangular profile. Prevents signal breakage and cable jams. Compact straight DIN 5-pin plug to flat angled 3.5 mm stereo jack plug (TRS). Black.

#### Type A (MIDI standard)

Pin assignment: MIDI 5 (Sink) - TRS tip, MIDI 4 (Source) - TRS ring, MIDI 2 (Shield) - TRS sleeve, MIDI 1 and MIDI 3 - not connected. Compatible with devices from Boss®, Empress®, Korg®, Akai®, MOD®, Make Noise® and many more.

Size	Product No.
30 cm / 11.81"	RBO CAB F TMA 30 BK
60 cm / 23.62"	RBO CAB F TMA 60 BK
150 cm / 59.06"	RBO CAB F TMA 150 BK

#### Type B

Pin assignment: MIDI 4 (Source) - TRS tip, MIDI 5 (Sink) - TRS ring, MIDI 2 (Shield) - TRS sleeve, MIDI 1 and MIDI 3 - not connected. Compatible with devices from Novation®, 1010Music®, Arturia®, Malekko®, Polyend®, Faderfox® and many more.

Size	Product No.
30 cm / 11.81"	RBO CAB F TMB 30 BK
60 cm / 23.62"	RBO CAB F TMB 60 BK
150 cm / 59.06"	RBO CAB F TMB 150 BK

## 2 Flat TRS to MIDI Cable



# Stay in the loop



## MIDI Cables

After the introduction of our original Flat MIDI Cables, we asked our design team to create an affordable MIDI Cable with a fully adjustable plug. The result? Our FlaX Plug MIDI Cable that is based on our Flat MIDI design, with compact, omni-directional plugs. Using two hex key screws, you can lock the FlaX Plug MIDI Cable into a straight or angled end. Anything goes with the FlaX MIDI Cables!

### 3 FlaX Plug MIDI Cable

Flat MIDI cable with omni-directional, lockable compact plugs. Plug orientation alterable from straight to angled to the left or right. Orientation lockable via 1.5 mm hex key wrench (not included). Flat rectangular cable, prevents cable breakage and cable jams. Compact DIN5-pin plugs. 5 x flexible oxygen-free copper conductors 5 x 7 x 0.12 mm. Suitable for Clock/SYNC Capabilities & Phantom Power. Max. rated current 1A. Outer insulation: PVC (Polyvinylchloride). Operating temperature: -20° C to +60° C (-4° F to 140° F). Dimensions plug (L x W x H): 33 x 20 x 15 mm / 1.30" x 0.79" x 0.59". Dimensions cable (W x H): 6.5 x 3.5 mm / 0.26" x 0.14".

Size	Product No.
30 cm / 11.81"	RBO CAB MD FX 30 BK
60 cm / 23.62"	RBO CAB MD FX 60 BK
100 cm / 39.37"	RBO CAB MD FX 100 BK
2 m / 6.5 ft	RBO CAB MD FX 200 BK
5 m / 16.4 ft	RBO CAB MD FX 500 BK

## 3 FlaX Plug MIDI Cable



# Effects pedal bags



## Specs for RockBoard® Effects Pedal Bags

- Strong, water-resistant RokTex® outer material
- 10 mm / 0.39" padding
- 2-way zipper (8 mm / 0.31" wide with nylon grip)
- Detachable, adjustable and padded shoulder strap
- Padded handles
- 1 front pocket for cables and accessories
- 1 interior accessory pocket
- PVC reinforced bottom
- Metal feet & hardware

### RockBoard® Effects Pedal Bags

These bags offer perfect protection for guitar and bass multi effects processors, voice multi effects processors, as well as looper switchers and MIDI controllers – for a bargain price!

Type	Internal Dimensions	Product No.
No. 01	20 x 18 x 10 cm / 7.87" x 0.71" x 3.94"	RBO EPB 01
No. 02	25 x 18 x 10 cm / 9.84" x 0.71" x 3.94"	RBO EPB 02
No. 03	30 x 22 x 10 cm / 11.81" x 8.66" x 3.94"	RBO EPB 03
No. 04	35 x 25 x 10 cm / 13.78" x 9.84" x 3.94"	RBO EPB 04
No. 05	40 x 30 x 12 cm / 15.75" x 11.81" x 4.72"	RBO EPB 05
No. 06	45 x 25 x 12 cm / 17.72" x 9.84" x 4.72"	RBO EPB 06
No. 07	50 x 30 x 12 cm / 19.69" x 11.81" x 4.72"	RBO EPB 07
No. 08	50 x 15 x 10 cm / 19.69" x 5.91" x 3.94"	RBO EPB 08
No. 09	55 x 30 x 12 cm / 21.65" x 11.81" x 4.72"	RBO EPB 09
No. 10	60 x 35 x 12 cm / 23.62" x 13.78" x 4.72"	RBO EPB 10
No. 11	70 x 35 x 12 cm / 27.56" x 13.78" x 4.72"	RBO EPB 11
No. 12	30 x 7 x 5 cm / 11.81" x 2.76" x 1.97"	RBO EPB 12
No. 13	40 x 8 x 7 cm / 15.75" x 3.15" x 2.76"	RBO EPB 13
No. 14	55 x 8 x 7 cm / 21.65" x 3.15" x 2.76"	RBO EPB 14

Front pocket for cables and accessories



Interior accessory pocket



Shoulder strap (35 mm / 1 3/8" wide)



PVC reinforced bottom



# Effects pedal suitcases



**1 Effects Pedal Case 01B**

**2 Effects Pedal Case 02 A**

**1 Effects Pedal Case 02 B**



**2 Effects Pedal Case 01 A**

Color	Internal Dimensions (W x D x H)	Weight	Product No.
Black	47 x 47,7 x 14,5 cm / 18.50" x 18.78" x 5.71"	4 kg / 8.8 lbs.	RBO EPC 01 B
Black	62 x 47,7 x 14,5 cm / 24.41" x 18.78" x 5.71"	4.5 kg / 9.9 lbs.	RBO EPC 02 B
Silver	47 x 47,7 x 14,5 cm / 18.50" x 18.78" x 5.71"	6.5 kg / 14.3 lbs.	RBO EPC 01 A
Silver	62 x 47,7 x 14,5 cm / 24.41" x 18.78" x 5.71"	8 kg / 17.6 lbs.	RBO EPC 02 A

**1 Effects Pedal Case 01/02 B**

Case for effects pedals with detachable lid. Durable and stable pedal case for 8 to 10 effects pedals (RBO EPC 01 B) or for 10 to 12 effects pedals (RBO EPC 02 B). Black PVC surface. Aluminium edging. Interior lined with hook and loop. Lid padded with nub foam. 2 locks. Nickel-plated steel spring handle with transparent PVC cover. PVC feet.

**2 Effects Pedal Case 01/02 A**

Case for effects pedals with detachable lid. Durable and stable pedal case for 8 to 10 effects pedals (RBO EPC 01 A) or for 10 to 12 effects pedals (RBO EPC 02 A). Silver PVC surface. Aluminium edging. Rugged, chrome plated ball corners. Interior lined with hook and loop. Lid padded with nub foam. 2 butterfly locks. Nickel-plated steel spring handle with transparent PVC cover. PVC feet.

2 locks



2 butterfly locks



Aluminium edging



Rugged, chrome plated ball corners



PVC feet



Interior lined with hook and loop



# Ready for the stage

StageTuner lets you always have your tuning in view.  
Be it in a 19 inch rack or right on the board in front of you.



**2 StageTuner ST-02**



**3 StageTuner ST-02 Power Adapter**

**1 StageTuner ST-01 V2**



**1 StageTuner ST-01 V2**

Chromatic pedal tuner for electric instruments. True bypass. 28 segment (FND) & LED display. Separate output for audible tuning. Tuning range A0 (27.5 Hz) - C8 (4186 Hz). Reference frequency 432 - 445 Hz (in 1 Hz steps). Detuning function with 3 settings (b / bb / bbb). Precision +/- 1 Cent. Power supply via included 9V battery or optional 9V DC power adapter (RockBoard® Power Ace), polarity (-) center, 2.1 x 5.5 mm barrel plug. By using the Quick-Mount Type M you can mount the StageTuner ST-01 V2 on your pedalboard. Dimensions (W x L x H): 73 x 110 x 47 mm / 2.87" x 4.33" x 1.85". Product No.: RBO E ST 01

**2 StageTuner ST-02**

19" Rack Tuner with detachable rack ears. Bright LED display with anti-glare front. Tuning range B1 (15.44 Hz) - C8 (4186 Hz). Tuning accuracy +/- 1 cent. Display modes: Normal, Strobe. Reference frequency adjustable from 432 - 445 Hz in 1Hz steps. Footswitchable bypass button on the front. Front-mounted calibrate button for selecting reference frequency. Compatibility with RockBoard® QuickMount® for RockBoard® pedalboard mounting (sold separately). Connections: 2 x 6.3 mm / 1/4" TS input (front and rear) 1 x 6.3 mm / 1/4" TS out (rear). 9V DC 2.1 x 5.5 mm barrel input. Incl. 9V DC power adapter and mounting screws. Dimensions (W x H x D): 489 x 45 x 63 mm / 19.25" x 1.77" x 2.48" (with rack ears) 399 x 45 x 63 mm / 15.71" x 1.77" x 2.48" (without rack ears). Product No.: RBO E ST 02

**3 StageTuner ST-02 Power Adapter**

Power adapter for RockBoard® StageTuner ST-02. 9V DC. 500 mA. 2.1 x 5.5 mm barrel plug. Polarity (-) center. 1.5 m (59") reinforced cable. Interchangeable multi-regional plug adapters (EU, UK, US/CA, AU/NZ). Input voltage 100-240V AC. Product No.: RBO E ST 02 PS

You can mount the StageTuner ST-02 on your pedalboard ... Or even in a 19 inch rack.



Calibrate the ST-02 to your preferences.



SOON

### 1 Natural Sound Buffer

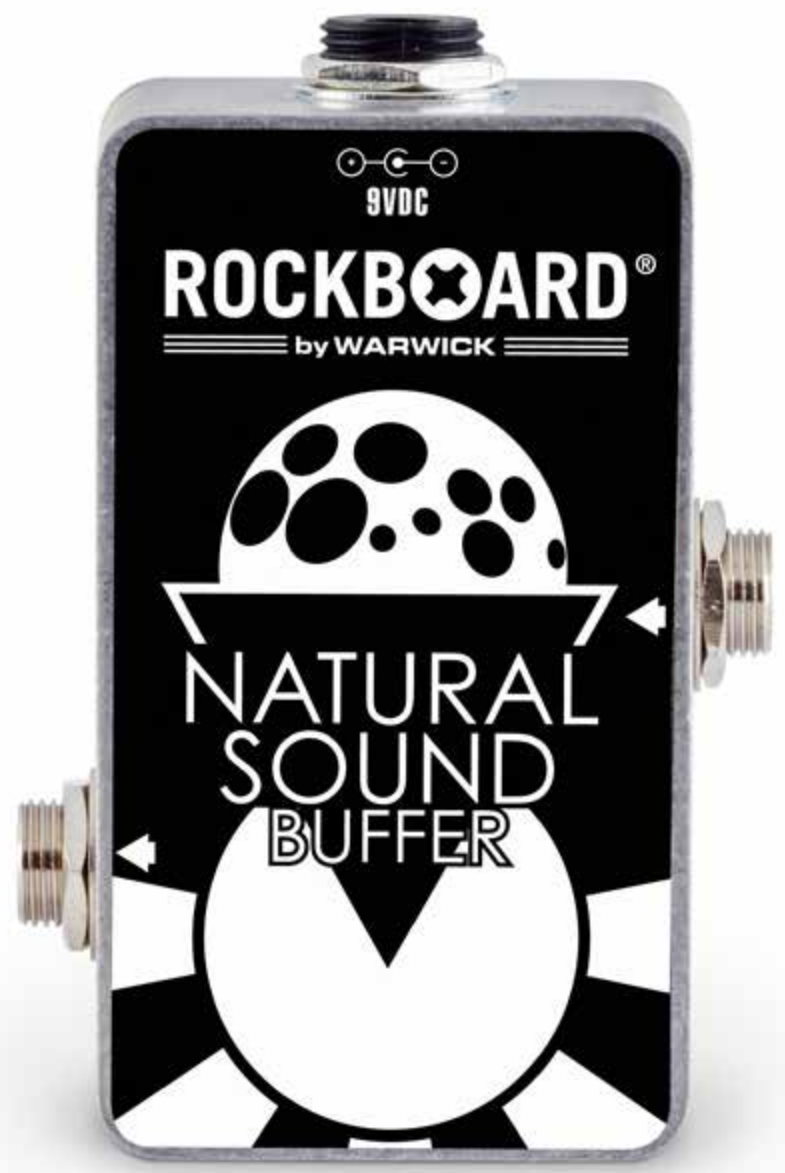

### 2 Power Attenuator



2 Power Attenuator  
Engineered to handle tube amps with impedances of 4, 8, and 16 ohms.  
Product No.: RBO E RPA 100

The Rockboard® Natural Sound Buffer is an op-amp based signal buffer that eliminates cable capacitance and loss of top end associated with long cable paths or using several unbuffered effects pedals. Its position in the signal chain should be ascertained by experimentation depending on the effects pedals used to optimize your sound.

1 Natural Sound Buffer  
Op-amp-based signal buffer. Prevents signal loss in effects chains. Solid metal housing. Power supply via optional 9V DC adapter, Battery operation not supported. Dimensions (W x D x H): 74 mm x 42 mm x 33 mm / 2.91" x 1.65" x 1.30".  
Product No.: RBO E NSB

### Power Attenuator



**Powerful Load Handling:** Capable of managing up to 100 watts, the RBO E RPA 100 ensures that your tube amp's raw power is harnessed and controlled to perfection.

**Impedance Versatility:** With selectable impedance options of 4, 8, and 16 ohms, this power attenuator provides flexibility to match your amplifier's requirements, delivering optimal performance.

**Silent Recording Excellence:** The RBO E RPA 100 enables you to crank up your tube amp to its sweet spot for that sought-after tone, all while capturing the sound directly through the active phones and to its Direct Input (DI) out with cab simulation.

**Versatile Connectivity:** The RBO E RPA 100 is equipped with a comprehensive set of connections, including Line Out and Aux In. This versatility allows seamless integration into your recording setup, providing endless creative possibilities.

**Precision Tone Crafting:** Fine-tune your sound with the integrated cab simulation, ensuring that your recordings faithfully reproduce the characteristics of a miked-up cabinet. Achieve studio-quality tones at any volume level.

### 1 Cable Set



NEW

### 2 Pedalboard Tape



### 3 Hook & Loop Tape



### 4 Cable Ties

Size	Color / Product No.					
	Black	Blue	Green	Orange	Red	Yellow
Set of 10 pcs.						
10 x 120 mm / 0.39" x 4.72"	RBO CAB TIE 120 B	RBO CAB TIE 120 BL	RBO CAB TIE 120 GR	RBO CAB TIE 120 OR	RBO CAB TIE 120 R	RBO CAB TIE 120 YE
20 x 200 mm / 0.79" x 7.87"	RBO CAB TIE 200 B	RBO CAB TIE 200 BL	RBO CAB TIE 200 GR	RBO CAB TIE 200 OR	RBO CAB TIE 200 R	RBO CAB TIE 200 YE
20 x 300 mm / 0.79" x 11.81"	RBO CAB TIE 300 B	RBO CAB TIE 300 BL	RBO CAB TIE 300 GR	RBO CAB TIE 300 OR	RBO CAB TIE 300 R	RBO CAB TIE 300 YE
40 x 400 mm / 1.57" x 15.75"	RBO CAB TIE 400 B	RBO CAB TIE 400 BL	RBO CAB TIE 400 GR	RBO CAB TIE 400 OR	RBO CAB TIE 400 R	RBO CAB TIE 400 YE
50 x 500 mm / 1.97" x 19.69"	RBO CAB TIE 500 B	RBO CAB TIE 500 BL	RBO CAB TIE 500 GR	RBO CAB TIE 500 OR	RBO CAB TIE 500 R	RBO CAB TIE 500 YE

### 1 Cable Set

**50 cable ties & 25 cable tie holders**  
Cable management for pedalboards, optimized for clean, quick routing and fixing of cable paths. Perfect for organizing flexible customization options on and under the pedalboard. Includes 50 cable ties 2 x 150 mm (black) and 25 holders for cable ties 20 x 20 mm (black). Proven 3M™ adhesive pad on the cable tie holders for a secure and powerful hold. Product No.: RBO CO SET 1

### 2 Pedalboard Tape, 100 cm

Pedalboard Tape for securely mounting effects pedals to the pedalboard. Proven 3M™ adhesive technology ensures a secure and firm hold for pedals of all types and sizes. Flexible organization of the pedals by simply cutting the tape to the desired size. Can be used like hook-and-loop tape but the interlocking hooks eliminate the need for a loop surface. 25 mm x 1 m. Product No.: RBO CO SET 2

### 3 Hook & Loop Tape

Self-adhesive Hook & Loop Tape is a simple but versatile solution for mounting effects pedals and power supplies on your pedalboard. The high-performance hook and loop tape ensures that your pedals stay in place. Effortlessly applied, it provides perfect adhesion for any pedal.

Size	Product No.
Narrow - 50 cm / 1.4 ft	RBO HL TAPE 25
Wide - 50 cm / 1.4 ft	RBO HL TAPE 50
Wide - 1 m / 3.3 ft	RBO HL TAPE 100
Wide - 2 m / 6.5 ft	RBO HL TAPE 200
Wide - 3 m / 9.8 ft	RBO HL TAPE 300
Wide - 5 m / 16.4 ft	RBO HL TAPE 500
Wide - 6 m / 19.7 ft	RBO HL TAPE 600

### 4 Cable Ties

The perfect solution for bundling, tying and organizing cables. Reusable and available in various sizes, they can easily be fixed to the cable. To make bundles more easily distinguishable, all different lengths are available in six colors!

### 5 StomPete



### 6 BigToe



### 5 Footswitch Topper StomPete

Available in black or silver. Set of 3 pcs.

**Black**

Product No.: RBO FT STOMPETE BK

**Silver**

Product No.: RBO FT STOMPETE SI

### 6 Footswitch Topper BigToe

Available in black or silver. Set of 3 pcs.

**Black**

Product No.: RBO FT BIGTOE BK

**Silver**

Product No.: RBO FT BIGTOE SI

Have you ever been blinded on stage? Not by the sweet halo of the limelight, but rather the cold shine of LEDs on your pedalboards? Now there is a solution. The RockBoard® LED Dampers are defractive caps for LEDs that will dampen the glare of bright LEDs on your pedals.

### 7 LED Damper

Defractive cover for LEDs. Dampens the glare of bright LEDs. Fits LEDs with or without bevel. Proven 3M™ adhesive technology ensures a secure and powerful hold. Set of 5 pcs.

**Size S: diameter 8 mm / 0.31"**

Product No.: RBO DAMPER S

**Size L: diameter 10.5 mm / 0.41"**

Product No.: RBO DAMPER L

### 8 Jewel LED Damper

Inside diameter 8 mm / 0.31". Dampens the glare of bright LEDs. Fits LEDs with or without bevel. Proven 3M™ adhesive technology ensures a secure and powerful hold. Set of 5 pcs.

**Size S: diameter 8 mm / 0.31"**

Product No.: RBO DAMPER JEWEL S

**Size L: diameter 10.5 mm / 0.41"**

Product No.: RBO DAMPER JEWEL L

## Footswitch Toppers

Footswitch toppers for effects pedals.

Enlarges the size of your footswitch for easier accessibility.

Fits most common footswitches.



### StomPete

- 1-piece design based on industrial emergency stop footswitches
- Held in place by a 1.5 mm hex key set screw
- Outside diameter (top) 24.3 mm
- Inside diameter 10.3 mm
- Additional height ca. 4.5 mm
- Made of anodized aluminum

### BigToe

- 2-piece design for tight fit and easy removal
- Outside diameter (top) 24.5 mm
- Inside diameter 9.5 mm (flexible)
- Additional height ca. 2.9 mm
- Made of anodized aluminum and thermoplastic rubber

### 7 LED Damper



### 8 Jewel LED Damper





# ROCKBOARD®

by WARWICK

## 1 T-Shirt



### 1 Promo - T-Shirt

Size S, M, L, XL, XXL

#### Tetris

Product No.:

PR T RBO TETRIS S/M/L/XL/XXL

#### Cartoon

Product No.:

PR T RBO CARTOON S/M/L/XL/XXL

### 2 Mobile Phone Stand

#### Aluminum Black

Product No.: PR RBO PHONE STAND B

#### Aluminum Silver

Product No.: PR RBO PHONE STAND S

### 3 Coffee Cup

Matte, black. 235ml / 8 oz.

Product No.: PR RBO PRO CUP BLK



## 2 Mobile Phone Stand

## 3 Coffee Cup

Note: The manufacturer reserves the right to change these specifications at any time and without prior notice.

USA DISTRIBUTION: W-Music Distribution USA | help@WUSAMusic.com | 629.202.6790

NORTH EUROPEAN DISTRIBUTION: W-Music Distribution | www.w-distribution.de | info@w-distribution.de

Headquarters: Warwick GmbH & Co. Music Equipment KG | 08258 Markneukirchen / Germany | +49 (0) 37422 / 555 - 0

Family Owned • Solar Powered • Sustainably Manufactured in a Green Environment

