**SA161**

DUAL EXPRESSION PEDAL

USER'S GUIDE

Thank you for purchasing the SA161 Dual Expression Pedal. This rugged, cast-aluminum expression pedal features two independent Expression Outputs as well as a Sensor Output for use with Source Audio Soundblox effects pedals. The dual TRS expression outputs allows the SA161 to control two Soundblox Pro (or other 3rd-party) units simultaneously.

The SA161 outputs are arranged on either side of the pedal. The two outputs have different functionality and are completely independent circuits.

OUTPUT 1 (right side):

- **EXP OUT 1 (TRS):** 50 kOhm passive expression output. Connect to an expression input on Soundblox Pro or 3rd-party effects pedals using the included ¼-inch TRS cable.
- **SENSOR OUTPUT:** Connect to the **SENSOR INPUT** on Soundblox, Soundblox 2, Soundblox Pro, and Hot Hand effects pedals. Connect using the included 4-conductor 3.5mm cable.

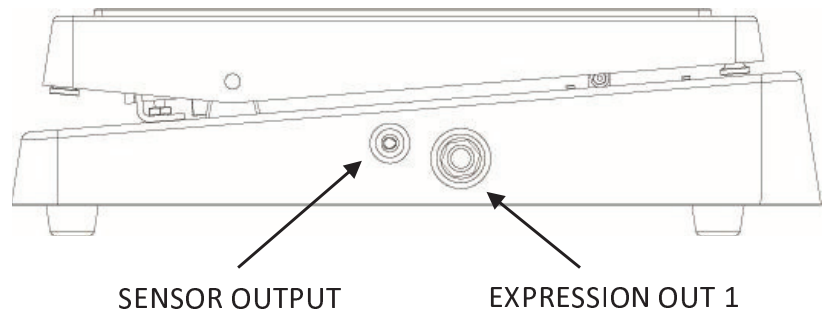

Note: Expression Output and Sensor Output can NOT be used simultaneously!

OUTPUT 2 (left side):

- **EXP OUT 2 (TRS):** 50 kOhm passive expression output.
- **RANGE ADJUST:** an additional 50 kOhm adjustment potentiometer is arranged in series with the EXP OUT 2 potentiometer. When the knob is fully clockwise, the range adjust has no effect. The knob can be turned counter-clockwise to reduce the range of the EXP OUT 2 pot.

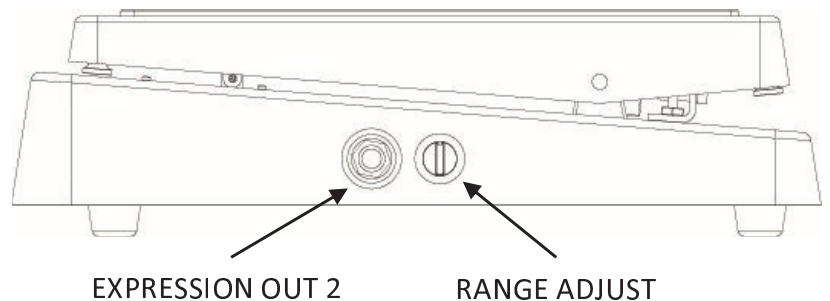

Note: The RANGE ADJUST only affects the EXP OUT 2.